



Atlas PCI-II
Pentium
ISA Motherboard

User's Guide

MAN-727
4/30/96

© Copyright 1985-2010 American Megatrends, Inc.
All rights reserved.
American Megatrends, Inc.
5555 Oakbrook Parkway, Building 200,
Norcross, GA 30093

This publication contains proprietary information which is protected by copyright. No part of this publication may be reproduced, transcribed, stored in a retrieval system, translated into any language or computer language, or transmitted in any form whatsoever without the prior written consent of the publisher, American Megatrends, Inc.

Limited Warranty

Buyer agrees if this product proves to be defective, that American Megatrends, Inc. is only obligated to replace or refund the purchase price of this product at American Megatrends' discretion according to the terms and conditions on the motherboard warranty card. American Megatrends shall not be liable in tort or contract for any loss or damage, direct, incidental or consequential. Please see the Warranty Registration Card shipped with this product for full warranty details.

Limitations of Liability

In no event shall American Megatrends be held liable for any loss, expenses, or damages of any kind whatsoever, whether direct, indirect, incidental, or consequential, arising from the design or use of this product or the support materials provided with the product.

Trademarks

Intel and Overdrive are registered trademarks of Intel Corporation.
VESA is a registered trademark of the Video Electronics Standards Association.
MS-DOS, Microsoft Word, and Microsoft are registered trademarks of Microsoft Corporation.
SMC is a registered trademark of SMC Corporation.
IBM, AT, VGA, PS/2, OS/2, and EGA are registered trademarks of International Business Machines Corporation.
XT and CGA are trademarks of International Business Machines Corporation.
Fujitsu is a registered trademark of Fujitsu America, Inc.
Motorola is a registered trademark of Motorola Corporation.
Hitachi is a registered trademark of Hitachi America, Ltd.
PNY is a registered trademark of PNY Corporation.
Oki is a registered trademark of Oki America, Inc.
NEC is a registered trademark of NEC Corporation.
Samsung is a registered trademark of Samsung Electronics Corporation.
Siemens is a trademark of Siemens Corporation.
Mitsubishi is a registered trademark of Mitsubishi Electronics of America.
Micron is a registered trademark of Micron Corporation.
Unix is a registered trademark of American Telephone and Telegraph Company Bell Laboratories.
Weitek is a trademark of Weitek, Inc.
Toshiba is a registered trademark of Kabushiki Kaisha Toshiba.
VESA, VBE/PM, and DPMS are trademarks of Video Electronics Standards Association.
All other brand and product names are trademarks or registered trademarks of their respective companies.

Revision History

9/30/95 Initial release of preliminary version.
11/3/95 Minor corrections to manual.
3/19/96 WINBIOS Setup option default settings were modified.
4/30/96 Updated manual.

Table of Contents

1 Hardware Installation.....	1
Atlas PCI-II Dimensions.....	2
Atlas PCI-II Motherboard Layout.....	4
Step 1 Unpack the Motherboard.....	5
Avoid Static Electricity.....	5
Step 2 Configure CPU.....	6
Step 3 Install Memory.....	12
Step 4 Install the Motherboard.....	18
Step 5 Attach Cables.....	20
Step 6 Test and Configure.....	37
2 WINBIOS Setup.....	39
Section 1 Setup.....	43
Standard Setup.....	43
Advanced Setup.....	46
Chipset Setup.....	52
Power Management Setup.....	56
Peripheral Setup.....	59
Section 2 Utility.....	71
Section 3 Security.....	72
AMIBIOS Password Support.....	72
Setting a Password.....	72
Changing a Password.....	73
Anti-Virus.....	73
Section 4 Default.....	74
3 Programming the Flash ROM.....	75
A Specifications.....	79
Appendix B Configuring an Offboard IDE Controller.....	81
Index.....	83

Preface

To the OEM Thank you for purchasing the high performance American Megatrends Atlas PCI-II ISA motherboard. This product is a state of the art motherboard that includes the famous AMIBIOS. It is assumed that you have also licensed the rights to use the American Megatrends documentation for the American Megatrends Atlas PCI-II motherboard

This manual was written for the OEM to assist in the proper installation and operation of this motherboard. This manual describes the specifications and features of the Atlas PCI-II motherboard. It explains how to assemble a system based on the Atlas PCI-II motherboard and how to use the AMIBIOS that is specifically designed for this motherboard.

This manual is not meant to be read by the computer owner who purchases a computer with this motherboard. It is assumed that you, the computer manufacturer, will use this manual as a sourcebook of information, and that parts of this manual will be included in the computer owner's manual.

Technical Support If an American Megatrends motherboard fails to operate as described or you are in doubt about a configuration option, please call technical support at 770-246-8645.

American Megatrends BBS

The American Megatrends BBS permits OEMs, VARs, and system integrators to access technical information about motherboard and BIOS products. Product Engineering Change Notices, Tech Tips, Technical Notes, and complete technical manuals are available.

Data Transmission Rates The American Megatrends BBS automatically handles modems with data transmission rates from 1,200 to 28,800 bps.

BBS Phone Numbers The following table lists the characteristics of the BBS phone numbers. The BBS requires no parity, eight data bits, and one stop bit.

Phone Number	Characteristics
770-246-8780	28,800 baud rate. Supports v.34.
770-246-8781	28,800 baud rate. Supports v.34.
770-246-8782	Supports HST and v.42.
770-246-8783	Supports HST and v.42.

Packing List

You should have received the following:

- an Atlas PCI-II motherboard,
 - two serial cables,
 - one parallel cable,
 - a Warranty Card, and
 - the *American Megatrends Atlas PCI-II Pentium ISA Motherboard User's Guide*
-

1 Hardware Installation

Overview

The American Megatrends Atlas PCI-II Pentium ISA motherboard features include:

- support for an Intel Pentium 3.3V CPU operating at 75, 90, 100, 120, 133, 150, 166, or 200 MHz,
- support for up to 256 MB of system memory,
- parity checking for system memory,
- interleaved memory,
- PCI local bus throughput of 132 megabytes per second,
- four ISA expansion slots, and
- four PCI expansion slots.

The motherboard conforms to the PCI Version 2.0 specification. The PCI slots are automatically configured by the AMIBIOS. The PCI slots operate synchronously with the CPU clock, as follows:

CPU External Clock Frequency	PCI Expansion Slot Frequency
66 MHz	33 MHz
60 MHz	30 MHz
50 MHz	25 MHz

Onboard I/O The Atlas PCI-II Pentium ISA motherboard includes:

- two 40-pin IDE connectors that support up to four IDE drives,
 - the onboard I/O connectors are on the PCI local bus,
 - a 34-pin floppy drive connector,
 - two 10-pin serial port connectors,
 - a 26-pin parallel port connector,
 - a keyboardminiDIN connector, and
 - a 10-pin berg mouse connector.
-

Atlas PCI-II Dimensions

The motherboard dimensions and height restrictions are shown below.

The Atlas PCI II motherboard is the standard baby AT size with the standard mounting holes.

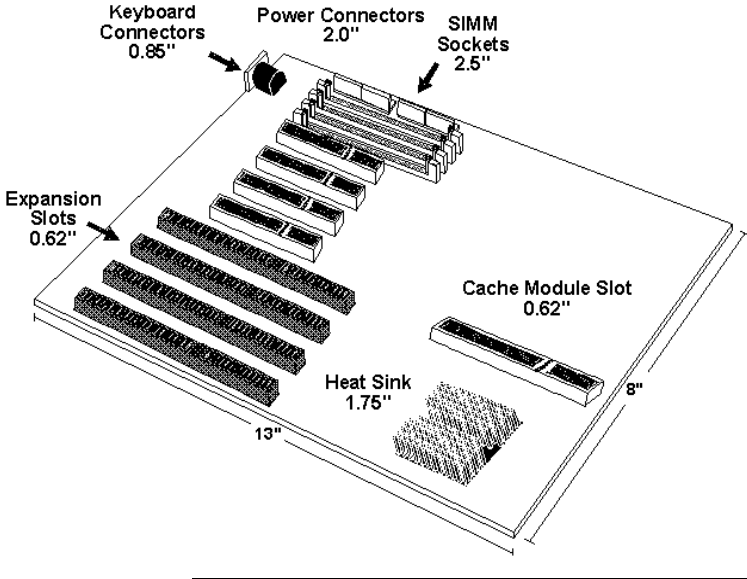

Installation Steps



Step	Action	Turn to
1	Unpack the motherboard.	Page5
2	Configure the CPU. Configure the CPU. Select the CPU 3.3V Power Source Select the CPU Voltage. Select the CPU Speed. Install the CPU.	Page6 Page6 Page6 Page8 Page8 Page10
3	Install memory.	Page12
	Install System Memory. Configure Cache Memory.	Page12 Page16
4	Install the Motherboard.	Page19
5	Attach cables to connectors.	Page22
	Attach VGA Connectors. Connect the Power Supply. Attach the Keyboard Cable. Connect the Mouse Cable. Attach Cables. Connect Onboard I/O. Connect the Serial Ports. Connect the Parallel Port. Connect Floppy Drive(s). Connect the IDE Drive(s).	Page22 Page27 Page30 Page31 Page31 Page31 Page31 Page31 Page33 Page38
6	Test and Configure.	Page45



Warning

This motherboard contains sensitive electronic components that can be easily damaged by static electricity. Follow the instructions carefully to ensure correct installation and to avoid static damage.

Atlas PCI-II Motherboard Layout

Pin 1 is identified by a square pin  and by a pointed box on the silkscreen. 

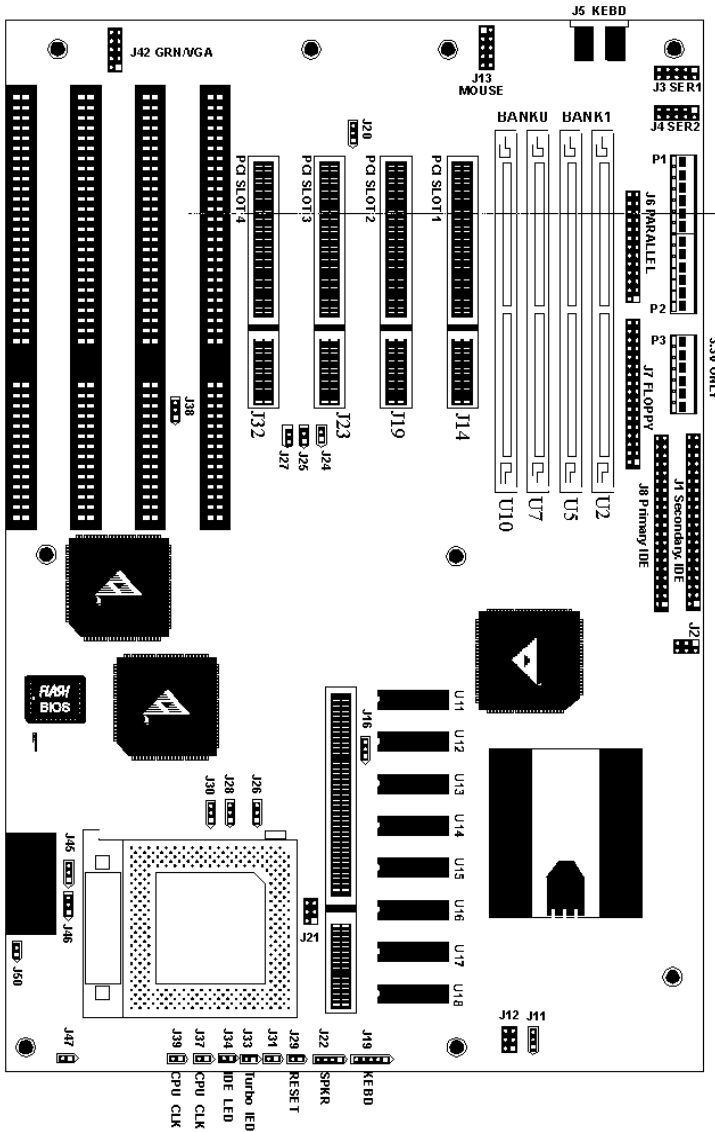

Step **Unpack the Motherboard**

Step	Action
1	Inspect the cardboard carton for obvious damage. If damaged, call 770-246-8645. Leave the motherboard in its original packing.
2	Perform all unpacking and installation procedures on a ground-connected antistatic mat. Wear an antistatic wristband grounded at the same point as the antistatic mat. Or use a sheet of conductive aluminum foil grounded through a megohm resistor instead of the anti-static mat. Similarly, a strip of conductive aluminum foil wrapped around the wrist and grounded through a megohm resistor serves the same purpose as the wristband.
3	Inside the carton, the motherboard is packed in an antistatic bag, and sandwiched between sheets of sponge. Remove the sponge and the anti-static bag. Place the motherboard on a grounded antistatic surface component side up. Save the original packing material.
4	Inspect the motherboard for damage. Press down on all ICs mounted in sockets to verify proper seating. Do not apply power to the motherboard if it has been damaged.
5	If the motherboard is undamaged, it is ready to be installed.

Set Jumpers Set all jumpers and install the CPU before placing the motherboard in the chassis.

Avoid Static Electricity

Static electricity can damage the motherboard and other computer components. Keep the motherboard in the anti-static bag until it is to be installed. Wear an anti-static wrist grounding strap before handling the motherboard. Make sure you stand on an anti-static mat when handling the motherboard. Avoid contact with any component or connector on any adapter card, printed circuit board, or memory module. Handle these components by the mounting bracket.

Step 2 Configure CPU

Jumpers J2, J11, J12, J21, J24, J25, J37, J39, and J46 are used to select the CPU type. See the drawing on page 4 for the jumper locations.



Important

Perform the following steps to configure the motherboard before installing any CPU.

3.3V CPU Power J21, J2, and J12 are six-pin bergs that select the 3.3V CPU power source. You can provide 3.3V in three different ways through three different power sources:

- regulator (default),
 - regulator and VRM, or
 - 3.3V power supply.
-

From Regulator Set J21, J2, and J12 as follows to configure 3.3V power from the regulator:

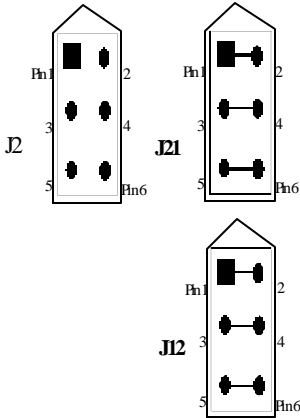

Cont'd

Step 2 Configure CPU, Continued

3.3V CPU Powercont'd

From Regulator and VRM at J21, J2, and J12 as follows to configure 3.3V power from the regulator and VRM:

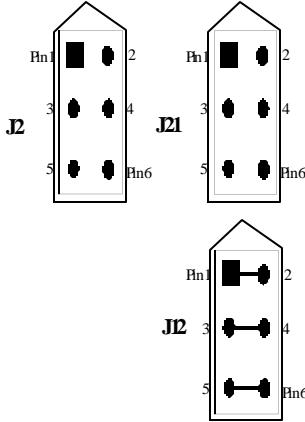

From 3.3V Power Supply at J21, J2, and J12 as follows to configure 3.3V power from the 3.3V power supply:

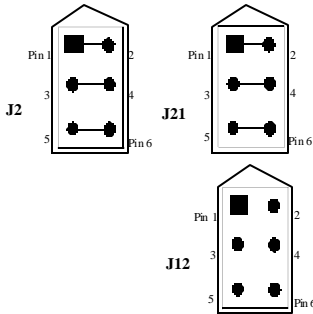

Cont'd

Step 2 Configure CPU, Continued

Select CPU Voltage The Atlas PCI-II motherboard supports Intel Pentium CPUs that adhere to either the standard or VRE voltage specifications. J11 is a three-pin berg that selects the CPU voltage.

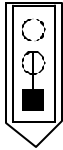

J11 Pins 1-2 Shorted
Standard CPU Voltage

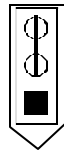

J11 Pins 2-3 Shorted
VRE CPU Voltage



Important

If you are not sure about the voltage specification for the CPU that will be installed in this motherboard, please call Intel and make sure that you set J11 correctly. Selecting the wrong voltage may damage the CPU.

Select CPU Speed J24, J25, J39, and J37 are two-pin bergs that together set the CPU speed.

CPU Speed	J25	J24	J39	J37
75 MHz	Shorted	Shorted	OPEN	OPEN
90 MHz	OPEN	Shorted	OPEN	OPEN
100 MHz	Shorted	OPEN	OPEN	OPEN
120 MHz	OPEN	Shorted	Shorted	OPEN
133 MHz	Shorted	OPEN	Shorted	OPEN
150 MHz	OPEN	Shorted	Shorted	Shorted
166 MHz	Shorted	OPEN	Shorted	Shorted
200 MHz	Shorted	OPEN	OPEN	Shorted



Important

Please contact American Megatrends technical support at 770-246-8645 to support a CPU running at a higher speed.

Cont'd

Step 2 Configure CPU, Continued

Connect CPU Fan J46 (shown below) is a two-pin berg that connects the fan on the CPU heat sink.



Pentium CPUs running at 75 and 90 MHz are shipped with a heat sink.

CPUs running at 100, 120, 133 MHz, or higher speeds are shipped *with heat sink and a CPU fan*. As shown below, the wire from the CPU fan has two leads. Connect the yellow lead to +12V (Pin 1 of J46).

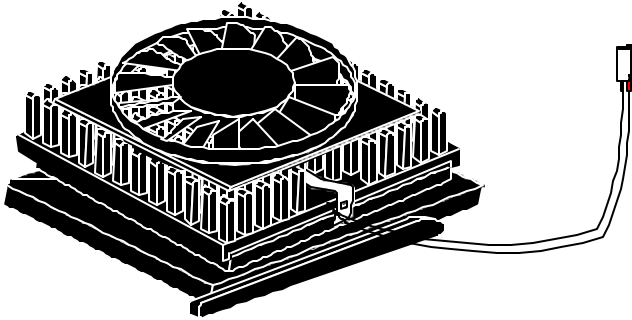

STOP

Warning



The yellow wire from the CPU fan must be connected to Pin 1 of J46.

Step 2 Configure CPU, Continued

Install CPU Install the CPU in the ZIF (zero insertion force) socket by performing the following steps. The CPU socket is near one edge of the motherboard, as shown on page 4.

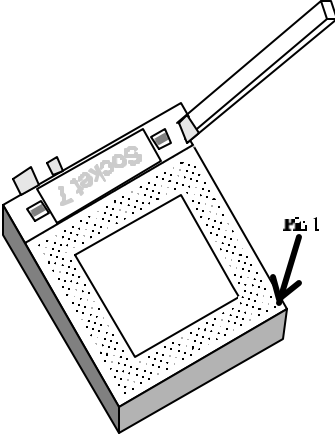
	<h3>Warning</h3> <p><i>Improper CPU installation can damage the CPU and the motherboard. You must follow the procedures in this section exactly as documented. Make sure you wear an antistatic wristband while installing the CPU. Follow all antistatic procedures described on page 5.</i></p>
---	---

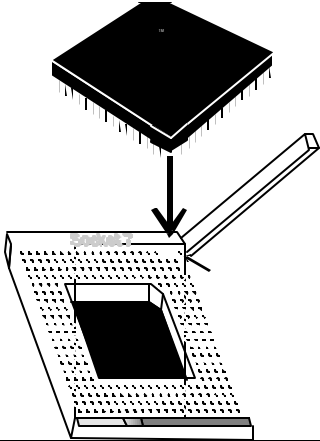
Step	Action
1	<p>Lift the lever on the ZIF socket. The empty CPU socket looks like this.</p> 

Step	Action
2	<p>Pin 1 of the socket has a white diagonal line across one corner on the motherboard, which corresponds to pin 1 of the CPU. Check for bent pins on the CPU. Gently straighten any bent pins with pliers. Place the CPU in the middle of the socket, as shown below. Make sure that pin 1 of the CPU is aligned with pin 1 of the socket. <i>Make sure you are properly grounded while handling the CPU.</i></p> 
3	<p>Complete installation by lifting the ZIF lever to the other side of the socket, as shown below.</p> 

Step 3 Install Memory

System Memory There are four 32-bit DIMM/SIMM – Single (or Double) Inline Memory Module) sockets. Memory must be populated one bank at a time. Each bank has two sockets. Bank0 includes U10 and U7. Bank1 includes U5 and U2. Each bank must be populated with the same type of SIMM/DIMM. If a 1 MB SIMM is installed in the first socket in Bank0, then the same type of 1 MB SIMM must be installed in the second Bank0 SIMM socket. Each socket can hold one SIMM or DIMM. You can use: 256 KB x 32 (or 36), 512 KB x 32 (or 36), 1 MB x 32 (or 36), 2 MB x 32 (or 36), 4 MB x 32 (or 36), 8 MB x 32 (or 36), or 16 MB x 32 (or 36) SIMMs.

The motherboard supports banks of fast page mode and EDO (Extended Data Out) memory together operating at 60 or 70 (RAS access time). Set the Chipset Setup **DRAM Speed for EDO** correctly if using EDO memory.

Memory Display System memory is reported by AMIBIOS as it boots and again when the AMIBIOS System Configuration Screen is displayed just before the operating system boots. The memory displayed by AMIBIOS on the System Configuration Screen is 384 KB less than the total memory installed.

Select SIMMs SIMMs must meet the following specifications:

Parameter	Specification
Page Mode	FAST
Refresh	CAS before RAS
t _{CAC}	≤ 20 ns
t _{RAC}	≤ 80 ns
t _{AA}	≤ 45 ns
t _{RP}	70 ns
t _{CPA}	≤ 45 ns

Cont'd

Step 3 Install Memory, Continued

SIMM Part Numbers

Type	Manufacturer	Part Number
256 KB x 36	Micron®	MT9D25636M-7
“	Mitsubishi®	MH26636BJ-7
“	Motorola®	MCM36256S-70
“	Oki®	MSC2320A-70YS9
“	PNY®	P36256-70
“	Samsung®	KMM536256B-7
1 MB x 36	Micron	MT12D136M-7
“	Mitsubishi	MH1M36ADJ-7
“	PNY	P361000-70
“	Motorola	MCM36100AS-70
“	Oki	MSC2355-70YS12
“	Samsung	KMM5361000AV-7
2 MB x 36	PNY	P362000-70
“	Samsung	EMM53620036-70
4 MB x 36	Micron	MT12D436M-7
“	Mitsubishi	MH4M36SAJ-7
“	Motorola	MCM36400S-70
“	PNY	P364000-70
“	Samsung	KMM5364100-7
8 MB x 36	Motorola	MCM36800S-70
“	PNY	P368000-707
“	Samsung	KMM53681007

Cont'd

Step 3 Install Memory, Continued

Installing SIMMs There are four x 36 SIMM sockets located on the Atlas PCI-II motherboard. These sockets can be filled with either 256 KB x 32 (or 36), 512 KB x 32 (or 36), 1 MB x 32 (or 36), 2 MB x 32 (or 36), 4 MB x 32 (or 36), 8 MB x 32 (or 36), or 16 MB x 32 (or 36) SIMMs.

Place the motherboard on an anti-static mat. With the component side of the SIMM facing you, firmly push the SIMM into the socket at an angle, then push it up. When properly inserted, the SIMM clicks into place as the latching pins engage. The SIMM installation process is shown below:

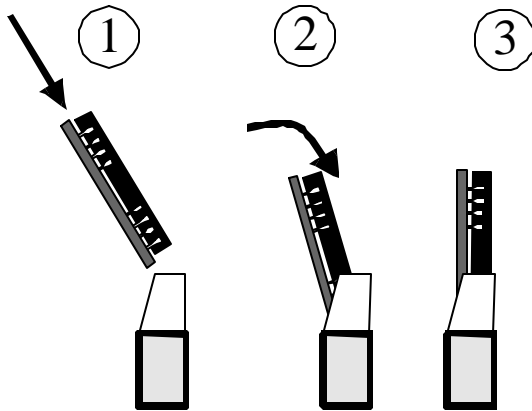

Cont'd

Step 3 Install Memory, Continued

Configure Cache Memory The Atlas PCI-II motherboard supports 256 KB, 512 KB or 1 MB of L2 cache memory. Cache memory is either surface-mounted SRAMs or a standard cache memory module.



Important

The Atlas PCI-II works with either the SMT cache memory or a cache module, but not both.

If the surface-mount cache memory is used, the cache module socket must be empty.

If a cache module is used, make sure that Pins 2-3 of J30 are shorted.

The cache module used must conform to the Intel COAST Version 1.0 specification. A 160-pin cache module connector is mounted on the motherboard.

Cache Jumpers J16, J26, J28, and J30 are three-pin bergs that select the external cache size and type.

SMT Cache The Atlas PCI-II motherboard is shipped with 256 KB of L2 secondary cache memory arranged as surface-mounted 32 KB x 8 SOJ chips.

J30



**Short Pins 1-2
for SMT Cache Enable**

Cont'd

Step 3 Install Memory, Continued

Configure Cache Memory

Specify the size of L2 secondary cache memory as shown in the following chart. Make sure you also set the **Cache Module Type** in WINBIOS Setup Chipset Setup. In the following drawing, Pin 1 of J16, J26, and J28 is represented by a square.

256 KB Asynchronous

J16 J26 J28



Set Cache Module Type in Chipset Setup to Async.

512 KB Asynchronous

J16 J26 J28



Set Cache Module Type in Chipset Setup to Async.

1 MB Asynchronous

J16 J26 J28



Set Cache Module Type in Chipset Setup to Async.

256 KB Burst or Pipeline Burst Cache

J16 J26 J28



Set the Cache Module Type in Chipset Setup to Burst if using a cache module that supports Burst mode.

Set it to Pipeline if using a cache module that supports pipelining.

512 KB Burst or Pipeline Burst

J16 J26 J28



Set the Cache Module Type in Chipset Setup to Burst if using a cache module that supports Burst mode.

Set it to Pipeline if using a cache module that supports pipelining.

1 MB Burst or Pipeline Burst

J16 J26 J28



Set the Cache Module Type in Chipset Setup to Burst if using a cache module that supports Burst mode.

Set it to Pipeline if using a cache module that supports pipelining.



Important

Before inserting the cache module:

- turn the computer off,
- make sure you follow all antistatic procedures,
- disable SMT cache by shorting Pins 2-3 of J30, and
- use only COAST 1.0-compliant cache modules.

Cont'd

Step 3 Install Memory, Continued

Upgrade Cache Select the SRAM module in the SRAM Type option in Chipset Setup in WINBIOS Setup. Insert the cache module as shown below:

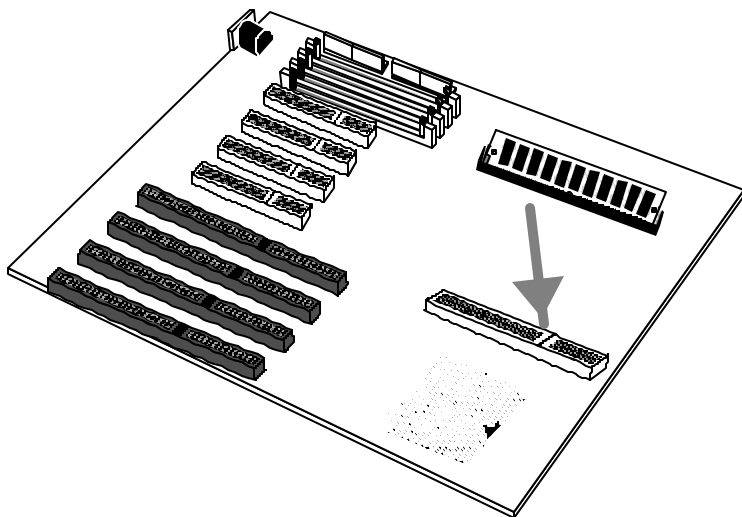

Step 4 Install the Motherboard

The motherboard mounting hole pattern is the same as the mounting hole pattern on the standard baby AT motherboard. Standoffs and mounting screws are not supplied with the motherboard. The chassis manufacturer should supply these parts.

Step	Action
1	Place the chassis on an antistatic mat. Connect the chassis to ground to avoid static damage during installation. Connect an alligator clip with a wire lead to any unpainted part of the chassis. Ground the other end of the lead at the same point as the mat and the wristband.
2	Rotate the chassis so the front is to the right, and the rear is to the left. The side facing you is where the motherboard is mounted. The power supply is mounted at the far end of the chassis.
3	Hold the motherboard, component side up, with the edge with the SIMM sockets toward you and the edge with the power supply connector away from you. The keyboard, mouse, and video connectors should be to the left.
4	Carefully slide the motherboard into the chassis. Make certain the edge connectors fit the ports in the rear of the chassis. The motherboard should rest level with the chassis.
5	Place the mounting screws in the holes provided and tighten them. If necessary, shift the motherboard slightly to align the mounting holes on the motherboard with the holes on the chassis. See the drawing on the next page.



Warning

If using metallic screws, make sure you use them only in the plated mounting holes. If using metallic screws, make sure the head of the screw fits completely inside the plated mounting holes.

See the graphic on the following page.

Cont'd

Step 4 Install Motherboard, Continued

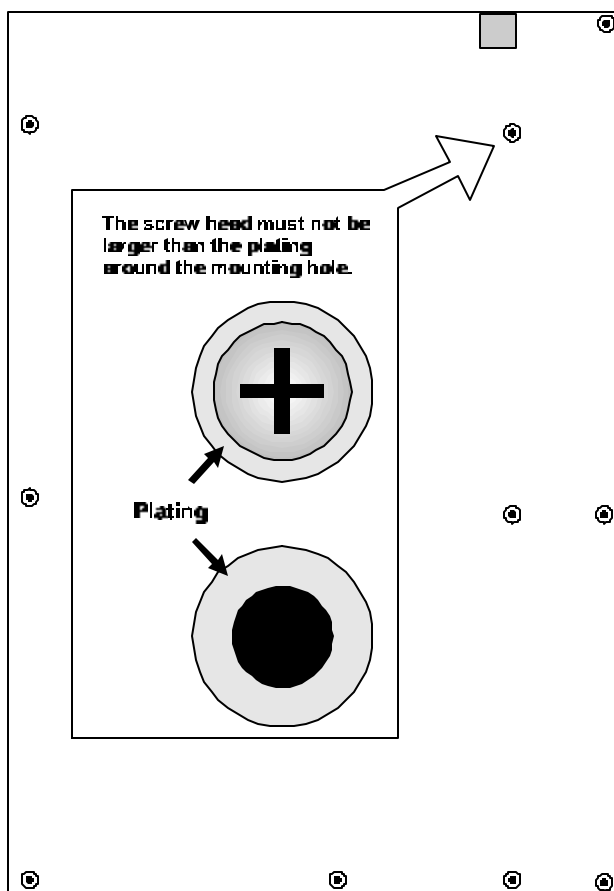

Step 5 Attach Cables

Connectors Connection instructions, illustrations, and pinouts follow. The connectors are:

Connector	Turn to
Green PC monitor connector J42 (optional)	page 23 through 25
Power supply connectors P1, P2, and P3	pages 27 through 30
Keyboard connector J5	page 30
Mouse connector J13	page 31
Green PC power supply connector J27	page 32
Reset switch J29	page 32
Speaker J22	page 32
Keyboard lock connector J19	page 33
Turbo LED connector J33	page 33
IDE LED connector J34	page 33
Serial port connectors J3 and J4	page 34
Parallel port connector J6	page 35
Floppy connector J7	page 36
IDE drive connectors J1 and J8	pages 41 through 44

Cable Connector Ends When connecting chassis connectors to the motherboard, make sure to connect the correct connector end. Most connector wires are color-coded. Match the color of the wires leaving the switch or LED to the same pin on the connector end. There may be more than one connector with the same color-coded wires. If so, follow the wire to the switch or LED. All motherboard components are outlined by a white rectangular box with a broad arrow at one end. Pin 1 is at the arrow end:

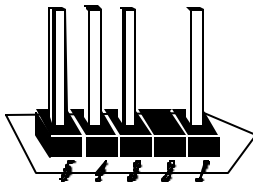

Cont'd

Step 5 Attach Cables, Continued

J42 Green PC Monitor J42 is a 10-pin connector that can be used to attach your monitor to the motherboard to allow AMIBIOS to conserve monitor power. If the VGA card in your computer is not DPMS-aware (Display Power Management Services), this connector provides a way to conserve monitor power. When AMIBIOS enters a power conserving mode, the motherboard logic signals the monitor to enter Sleep mode. This works if the monitor is DPMS-aware.

Almost all newer PCI VGA cards support DPMS through the VGA BIOS. The computer enters Sleep mode, AMIBIOS makes a DPMS call to the VGA BIOS. The VGA BIOS then signals the monitor to enter Sleep mode. *If you are using a PCI VGA card, you probably do not need to use this connector.*

The J42 pinout is:

Pin	Signal Description	Pin	Signal Description
1	N/C	2	N/C
3	N/C	4	N/C
5	TTL output for SYNC enable	6	Open Collector output for HSYNC control
7	N/C	8	Open Collector output for VSYNC control
9	N/C	10	GND

The J42 connector pins are arranged as follows:

1	2
3	4
5	6
7	8
9	
10	

Cont'd

Step 5 Attach Cables, Continued

J42 Connector Attach a special cable, which can be ordered from American Megatrends (Part Number CBL-SUB2-25) between J42 and the VGA Feature Connector on the VGA card or graphics accelerator, as shown below:

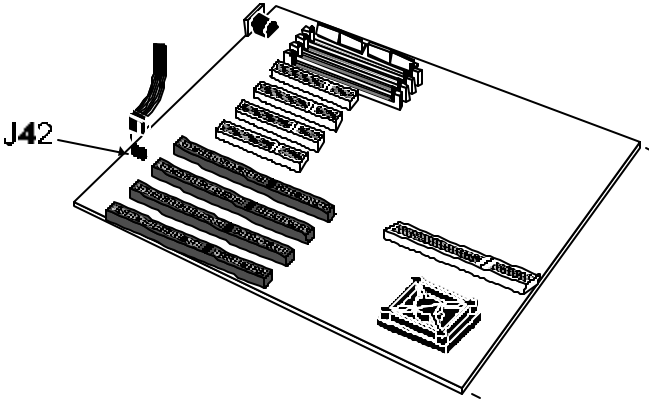

VGA Cable The VGA feature connector cable is shown below.

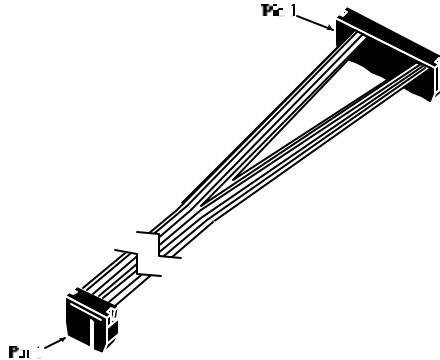

After the timeout period specified in Power Management Setup expires, the motherboard drives the SYNC ENABLE, HSYNC, and VSYNC signals Low through open collector outputs. Monitors that support DPMS can turn power off after examining this condition, saving power.

Cont'd

Step 5 Attach Cables, Continued

Connect Power Supply The power supply should match the physical configuration of the chassis. Make sure the power switch is off before assembly.

Before attaching all components, make sure the proper voltage has been selected. Power supplies often can run on a wide range of voltages and must be set (usually via a switch) to the proper range. Use at least a 200 watt power supply, which should have built-in filters to suppress radiated emissions.

Connect Power Cables Attach the power supply cables to the power connector (CN1) on the motherboard. AT-compatible power supplies have two six-pin connectors, attached as shown below. The six-pin connector on the power cable with three red wires and two black wires is attached to CN1 Pins 7-12. The other connector on the end of the power cable is attached to CN1 pins 1-6.

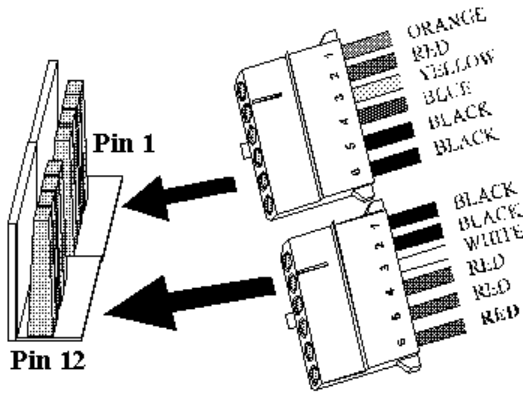

Power Supply Connector

Cont'd

Step 5 Attach Cables, Continued

Power Connector Keys The power connectors are keyed to prevent incorrect installation. The keys on the connector must be cut to fit on some power supplies, as shown below.

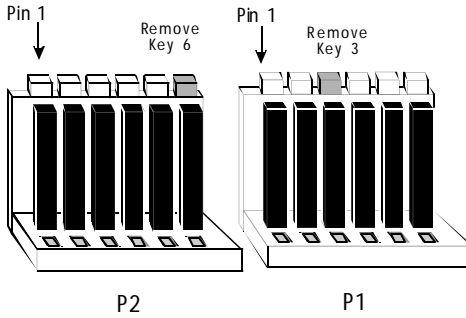

P1 Pinout

Pin	Description
1	Power Good (Orange wire) (Not used)
2	VCC (Red wire)
3	+12 Volts (Yellow wire)
4	-12 Volts (Blue wire)
5	Ground (Black wire)
6	Ground (Black wire)

P2 Pinout

Pin	Description
1	Ground (Black wire)
2	Ground (Black wire)
3	-5 Volts (White wire)
4	VCC (Red wire)
5	VCC (Red wire)
6	VCC (Red wire)

Cont'd

Step 5 Attach Cables, Continued

P3 Pinout P3 provides 3.3V power.

Pin	Description
1	Ground (Black wire)
2	Ground (Black wire)
3	-5 Volts (White wire)
4	3.3V
5	3.3V
6	3.3V

Keyboard Connector The keyboard connector (J5) is a six-pin DIN socket. The J5 pinout is shown below. The keyboard connector position is shown on page 4.

Pin	Assignments
1	Keyboard clock
2	Keyboard data
3	Not used
4	Ground
5	VCC

Step 5 Attach Cables, Continued

Connect Mouse Cable The mouse connector (J13) is a 10-pin berg. The mouse cable is the same as the serial cable in the Atlas PCI-II motherboard. Two serial cables are shipped with the motherboard. Use one of these cables for the mouse, or you can make your own cable using the following pinouts.

Pin	Description	Pin	Description
1	Mouse Clock	2	N/C
3	N/C	4	N/C
5	N/C	6	VCC
7	N/C	8	Mouse Data
9	Ground	10	N/C

Mouse IRQ

J38 is a three-pin berg that enables the PS/2 mouse interrupt (IRQ12). Short Pins 1-2 of J38 to enable IRQ12 as the PS/2 mouse interrupt. You should always short Pins 1-2 of J38 to enable the PS/2 mouse interrupt. The only reason you would ever have to short Pins 2-3 of J38 is if you wanted an adapter card on the ISA bus to use IRQ12. You would then have to set the **PS/2 Mouse** option in Advanced Setup to **Disabled**, and set the **IRQ12** option in Advanced Setup to **ISA**. Enable or disable the PS/2 mouse by setting the **PS/2 Mouse** option in Advanced Setup in WINBIOS Setup to **Enabled** or **Disabled**.



J38 Pins 1-2 Shorted
IRQ12 used for PS/2 Mouse

Cont'd

Step 5 Attach Cables, Continued

J27 Green PC Power J27 is a two-pin berg that connects to a Green PC power supply. When the computer enters a power conserving state, a signal is sent from this berg to the power supply to permit the power supply to switch to a low power, high-efficiency mode.

The + on Pin 2 identifies the positive connector.

J29 Reset Switch Connector J29 is a two-pin single-inline berg that is attached via a cable to an externally-mounted reset switch.

When the reset switch is pressed, the system performs a hard reset. Pin 1 is ground and Pin 2 is Hard Reset.

J22 Speaker Connector J22 is a four-pin single-line berg that is optionally attached via a cable to a standard system speaker. AMIBIOS signals hardware problems through the speaker. Pin 1 on the motherboard is identified by the arrow on the white box around the berg. The Atlas PCI-II motherboard also has a built-in speaker mounted on the motherboard.

Pin	Description
1	Data Out
2	Key
3	N/C
4	VCC

Cont'd

Step 5 Attach Cables, Continued

Keyboard Lock J19 is a five pin single line berg that is attached via a cable to the keyboard lock connector (or separate keyboard lock and Power LED connectors). The computer chassis may not include the keyboard lock and Power LED on a single connector. The keyboard lock allows the user to lock the keyboard, protecting the system from unauthorized use. Pin 1 on the motherboard is identified by the broad arrow.

Pin	Description
1	VCC
2	N/C
3	Ground
4	Keyboard Lock (KBDINH)
5	Ground

J33 Turbo LED J33 is a two-pin berg that is attached via a cable to the externally-mounted bipolar Turbo LED. The LED lights when the motherboard is running at high speed.

J34 IDE LED J34 is a two-pin berg that is attached via a cable to the externally-mounted IDE Activity LED. This LED lights when the IDE drive is running.

	<p>Warning</p> <p>In some IDE drives, you may have to disable the IDE LED mounted on the drive by changing a jumper or setting a switch on the IDE drive itself, before the IDE drive sends a signal to J34.</p>
---	---

Cont'd

Step 5 Attach Cables, Continued

Onboard Adapters The Atlas PCI-II motherboard has:

- two serial ports (J3 and J4),
- a parallel port (J6),
- an IDE controller on the PCI bus. The primary IDE connector is J8. The secondary connectors is J1.
- a floppy controller (J7).

The serial and parallel port connectors are described below. The IDE connector is described on [page 38](#).
The floppy connector is described on [page 39](#).

Conflicts AMIBIOS minimize conflicts between onboard and offboard I/O devices.

AMIBIOS automatically checks the adapter cards installed in the expansion slots on the Atlas PCI-II motherboard for a hard disk or floppy controller and serial or parallel ports.

J3 SER1 J3 and J4 are 10-pin connectors that provide an AT-compatible serial port interface. Connect the cables supplied with the motherboard to J3 and J4. The serial port base I/O port address and other serial port settings can be selected in Peripheral Setup in WINBIOS Setup.

The J3 and J4 pinout is shown below.

Pin	Description	Pin	Signal Description
1	Carrier Detect	6	Data Set Ready
2	Receive Data	7	Request to Send
3	Transmit Data	8	Clear to Send
4	Data Terminal Ready	9	Ring Indicator
5	Ground	10	CUT PIN

Cont'd

Step 5 Attach Cables, Continued

J6 Parallel Port J6 is a 26-pin connector for a parallel port. The J6 pinout is shown below. Connect the 16-pin to DB25 cable provided with the motherboard to J6.

All parallel port settings can be configured through Peripheral Setup in WINBIOS Setup.

Pin	Signal Description	Pin	Signal Description
1	STROBE#	2	PD0
3	PD1	4	PD2
5	PD3	6	PD4
7	PD5	8	PD6
9	PD7	10	ACK#
11	BUSY	12	PE
13	SLCT	14	AUTOFD#
15	ERROR#	16	INIT#
17	SLCTIN#	18	Ground
19	Ground	20	Ground
21	Ground	22	Ground
23	Ground	24	Ground
25	Ground	26	Ground

Cont'd

Step 5 Attach Cables, Continued

J7 Floppy

J7 is a 34-pin dual-inline berg. Connect the cable from the floppy drive to J7, as shown below. The onboard floppy controller cannot be used if a hard disk card with a floppy controller is installed. Choose Standard Setup and Peripheral Setup to configure the floppy controller.

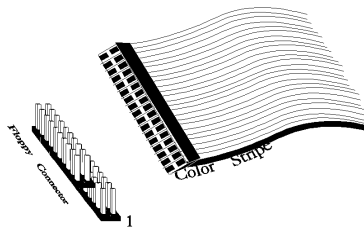

The motherboard supports up to two 720 KB, 1.44 MB, or 2.88 MB 3½" drives or 360 KB and 1.2 MB 5¼" drives. The connecting cable is a 34-pin ribbon connector with two 34-pin edge connectors for attaching the floppy disk drives. There is a small twist in the cable between the floppy connectors. Attach the last connector as shown below.

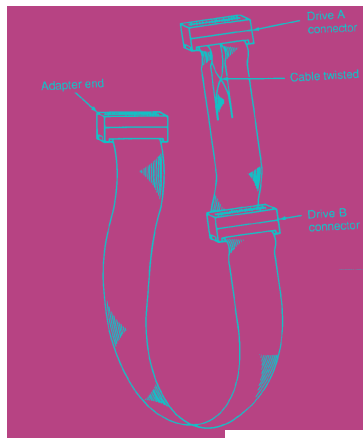

Cont'd

Step 5 Attach Cables, Continued

J7 Floppy Connector Pinout

Pin	Use	Pin	Use
1	GND	2	DENSE1
3	GND	4	N/C
5	GND	6	DRATE0
7	GND	8	-INDEX
9	GND	10	-MOTOR0
11	GND	12	-FDSEL1
13	GND	14	-FDSEL0
15	GND	16	-MOTOR1
17	GND	18	DIR
19	GND	20	-
21	GND	22	-WDATA
23	GND	24	-WGATE
25	GND	26	-TRK0
27	GND	28	-WRPROT
29	GND	30	-RDATA
31	GND	32	HDSEL
33	GND	34	DSKCHNG

Twist in Floppy Cable

Floppy B to A	Floppy B to A	Floppy B to A	Floppy B to A
10 to 16	12 to 14	14 to 12	16 to 10
11 to 15	13 to 13	15 to 11	

Cont'd

Step 5 Attach Cables, Continued

IDE Drives Attach the IDE drives in the following manner. Choose Peripheral Setup in WINBIOS Setup to enable the onboard IDE controller.

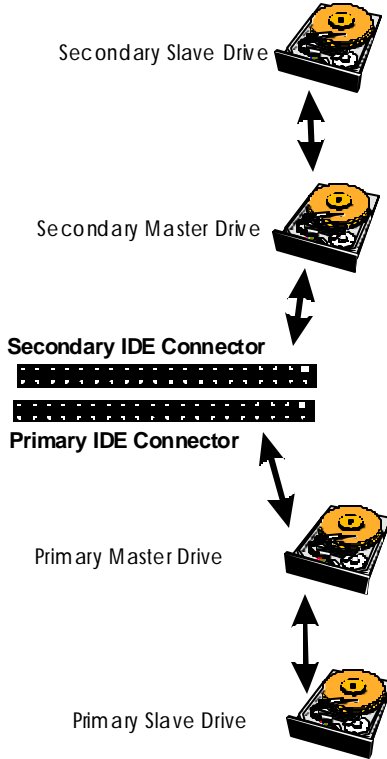

Cont'd

Step 5 Attach Cables, Continued

Attach IDE Cable to J8 J8 is the primary IDE (Integrated Drive Electronics) hard disk drive connector. Both the primary master and the primary slave IDE drives must be connected by cable to J8, as shown below.

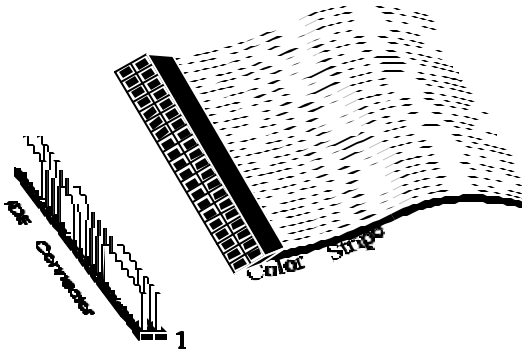

J8 is a 40-pin dual-inline berg that connects an IDE drive to the primary onboard IDE connector. This motherboard supports IDE Modes 0, 1, 2, 3, and 4, IDE prefetch, LBA (Logical Block Address) mode, high capacity drives (over 528 MB), 32-bit data transfer, and fast IDE transfer. These IDE features are configured in Peripheral Setup in the WINBIOS Setup utility.

Disable the onboard IDE interface in Peripheral Setup to use an ISA ESDI, RLL, MFM, or SCSI hard disk drive controller.

Install IDE Drivers American Megatrends provides IDE drivers for the onboard IDE controller. These drivers are unnecessary if running in DOS, but must be loaded for other operating systems. These drivers have not been tested with Novell NetWare or SCO Unix.

Operating System	Description
Windows 3.11 and Windows for Workgroups	Load the PIO drivers for 32-bit access.
Windows 95	Always load the IDE drivers.
Windows NT v3.x	Always load the IDE drivers.
OS/2	Always load the IDE drivers.

Cont'd

Step 5 Attach Cables, Continued

J8 Pinout The J8 pinout is:

Pin	Use	Pin	Use
1	-RESET	2	GND
3	DATA7	4	DATA8
5	DATA6	6	DATA9
7	DATA5	8	DATA10
9	DATA4	10	DATA11
11	DATA3	12	DATA12
13	DATA2	14	DATA13
15	DATA1	16	DATA14
17	DATA0	18	DATA15
19	GND	20	KEY (N/C)
21	N/C	22	GND
23	-IOW	24	GND
25	-IOR	26	GND
27	IDERDY	28	ALE
29	N/C	30	GND
31	INT14	32	-IOCS16
33	HA1	34	N/C
35	HA0	36	HA2
37	-CS0	38	-CS1
39	-IDEACT	40	GND

J1 Secondary IDE Controller J1, the secondary IDE connector, is a 40-pin dual-inline berg that connects the secondary primary and slave IDE drives to the secondary onboard IDE controller.

Attach the secondary master and slave IDE drives to J1 via a standard 40-pin IDE cable as shown on page 41.

Cont'd

Step 5 Attach Cables, Continued

J1 Pinout The J1 pinout is:

Pin	Use	Pin	Use
1	-RESET	2	GND
3	DATA7	4	DATA8
5	DATA6	6	DATA9
7	DATA5	8	DATA10
9	DATA4	10	DATA11
11	DATA3	12	DATA12
13	DATA2	14	DATA13
15	DATA1	16	DATA14
17	DATA0	18	DATA15
19	GND	20	KEY (N/C)
21	N/C	22	GND
23	-IOW	24	GND
25	-IOR	26	GND
27	IDERDY	28	ALE
29	N/C	30	GND
31	INT15	32	-IOCS16
33	HA1	34	N/C
35	HA0	36	HA2
37	-CS2	38	-CS3
39	N/C	40	GND

Step 6 Test and Configure

Review the following points before powering up:

- make sure that all adapter cards are seated properly,
 - make sure all connectors are properly installed,
 - make sure the CPU is seated properly,
 - make sure there are no screws or other foreign material on the motherboard,
 - plug the system into a surge-protected power strip, and
 - make sure blank back panels are installed on the back of the chassis to minimize RF emissions.
-

Start the Test Plug everything in and turn on the switch. If there are any signs of a problem, turn off the unit immediately. Reinstall the connectors. Call Technical Support if there are problems.

BIOS Errors If the system operates normally, a display should appear on the monitor. The BIOS Power On Self Test (POST) should execute.

If POST does not run successfully, it will beep or display error messages. Beeps indicate a serious problem with the system configuration or hardware. The Beep Code indicates the problem. AMIBIOS Beep Codes are defined ~~the~~ *AMIBIOS Technical Reference*. Make sure the affected part is properly seated and connected. An error message is displayed if the error is less serious. Recheck the system configuration or the connections.

Configure the System Run WINBIOS Setup. You must enter the requested information and save the configuration data in CMOS RAM. The system will then reset, run POST, and boot the operating system. See [page 54](#) for information on configuring the computer.

2 WINBIOS Setup

In ISA and EISA computers, the system parameters (such as amount of memory, type of disk drives and video displays, and many other elements) are stored in CMOS RAM. Unlike the DRAM (dynamic random access memory) that is used for standard system memory, CMOS RAM requires very little power. When the computer is turned off, a back-up battery provides power to CMOS RAM, which retains the system parameters. Every time the computer is powered-on, the computer is configured with the values stored in CMOS RAM by the system BIOS, which gains control when the computer is powered on.

The system parameters are configured by a system BIOS Setup utility. Historically, BIOS Setup utilities have been character-based, required keyboard input, and have had user interfaces that were not very intuitive.

New BIOS Setup American Megatrends has a new type of system BIOS Setup utility. WINBIOS Setup has a graphical user interface the end user can access using a mouse. The WINBIOS Setup code is so compact that it can reside on the same ROM as the system BIOS. The system configuration parameters are set by WINBIOS Setup.

Since WINBIOS Setup resides in the ROM BIOS, it is available each time the computer is turned on.

Starting WINBIOS Setup As POST executes, the following appears:

Hit if you want to run SETUP

Press to run WINBIOS Setup.

Using a Mouse with WINBIOS Setup

WINBIOS Setup has a built-in mouse driver and can be accessed by either a serial mouse or PS/2-style mouse. WINBIOS Setup supports Microsoft-Compatible serial mice and all PS/2-type mice.

The mouse click functions are: single click to change or select both global and current fields and double-click to perform an operation in the selected field.

Using the Keyboard with WINBIOS Setup

WINBIOS has a built-in keyboard driver that uses simple keystroke combinations:

Keystroke	Action
<Tab>	Change or select a global field.
<→, ←, ↑, ↓>	Change or select the current field.
<Enter>	Perform an operation in the current field
+	Increment a value.
-	Decrement a value.
<Esc>	Abort any window function.
<PgUp>	Return to the previous page
<PgDn>	Advance to the next page.
<Home>	Returns to the beginning of the text.
<End>	Advance to the end of the text.
<Ctrl><Alt><+>	Change to high speed
>	
<Ctrl><Alt><->	Change to low speed.

WINBIOS Setup Menu

The WINBIOS Setup main menu, shown below, is organized into four sections. Each of these sections corresponds to a section in this chapter.

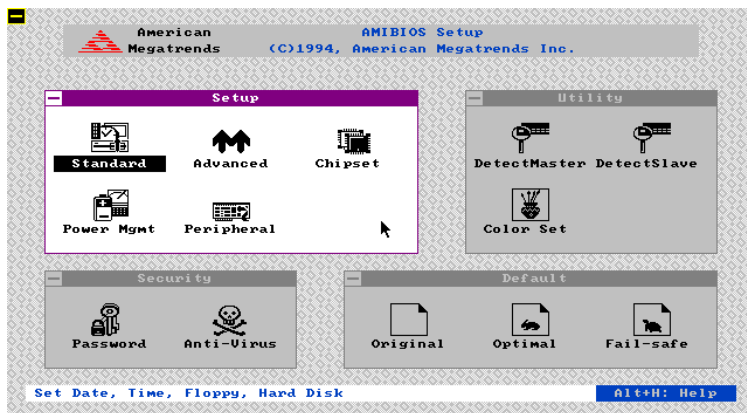

Each section contains several icons. Clicking on each icon activates a specific AMIBIOS function. The WINBIOS Setup main windows and related functions are described on the next page.

Cont'd

WINBIOS Setup Menu, Continued

Main Windows The WINBIOS Setup main windows are:

- Setup, described in Section 1 on page 54, has icons that permit you to set system configuration options such as date, time, hard disk type, floppy type, and many others,
 - Utilities, described in Section 2 beginning on page 88, has four icons that perform system functions,
 - Security, described in Section 3 beginning on page 89, has two icons that control AMIBIOS security features, and
 - Default, described in Section 4 beginning on page 93, this section has three icons that permit you to select a group of settings for all AMIBIOS WINBIOS Setup options.
-

Section 1 Setup

Standard Setup

Standard Setup options are displayed by choosing the Standard icon from the WINBIOS Setup main menu. All Standard Setup options are described in this section. The Standard Setup screen follows.

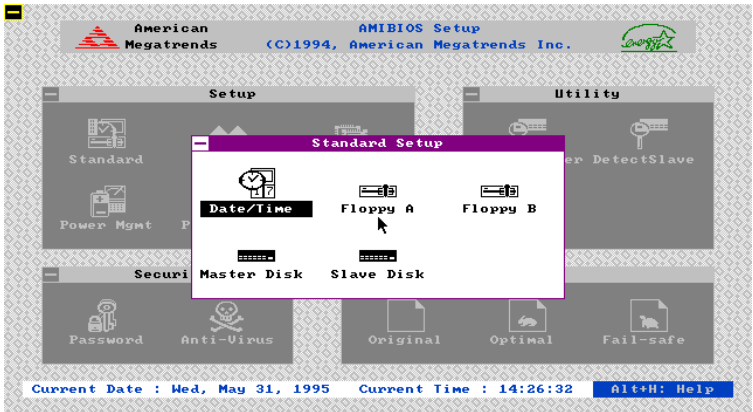

Date/Time Select the Standard option. Select the Date and Time icon. The current values for each category are displayed. Enter new values through the keyboard.

Floppy Drive A: and B Move the cursor to these fields \uparrow and \downarrow and select the floppy type. The settings are 360 KB 5¼ inch, 1.2 MB 5¼ inch, 720 KB 3½ inch, 1.44 MB 3½ inch, or 2.88 MB 3½ inch.

Standard Setup, Continued

Primary Master, Primary Slave Select one of these hard disk drive icons to configure the hard disk drive named in the option. A scrollable screen that lists all valid disk drive types is displayed. Select the correct type and press <Enter>.

Detecting IDE Parameters If you select Detect Master or Detect Slave from the Utility section of the WINBIOS Setup main menu, AMIBIOS automatically finds all IDE hard disk drive parameters for that drive. Before automatically detecting IDE drives, make sure the **Onboard IDE** option in Peripheral Setup is set to *Enabled*.

AMIBIOS places the hard disk drive parameters it finds in the Master Disk or Slave Disk fields in Standard Setup.

Entering Drive Parameters You can also enter the hard disk drive parameters. The drive parameters are:

Parameter	Description
Type	The number for a drive with certain identification parameters.
Cylinders	The number of cylinders in the disk drive.
Heads	The number of heads.
Write Precompensation	The size of a sector gets progressively smaller as the track diameter diminishes. Yet each sector must still hold 512 bytes. Write precompensation circuitry on the hard disk compensates for the physical difference in sector size by boosting the write current for sectors on inner tracks. This parameter is the track number where write precompensation begins.
Landing Zone	This number is the cylinder location where the heads will normally park when the system is shut down.
Sectors	The number of sectors per track. MFM drives have 17 sectors per track. RLL drives have 26 sectors per track. ESDI drives have 34 sectors per track. SCSI and IDE drive may have even more sectors per track.
Capacity	The formatted capacity of the drive is the number of heads times the number of cylinders times the number of sectors per track) times 512 (bytes per sector).

Cont'd

Standard Setup, Continued

Hard Disk Drive Types

Type	Cylinders	Heads	Write Precompensation	Landing Zone	Sectors	Capacity
1	306	4	128	305	17	10 MB
2	615	4	300	615	17	20 MB
3	615	6	300	615	17	31 MB
4	940	8	512	940	17	62 MB
5	940	6	512	940	17	47 MB
6	615	4	65535	615	17	20 MB
7	462	8	256	511	17	31 MB
8	733	5	65535	733	17	30 MB
9	900	15	65535	901	17	112 MB
10	820	3	65535	820	17	20 MB
11	855	5	65535	855	17	35 MB
12	855	7	65535	855	17	50 MB
13	306	8	128	319	17	20 MB
14	733	7	65535	733	17	43 MB
16	612	4	0	663	17	20 MB
17	977	5	300	977	17	41 MB
18	977	7	65535	977	17	57 MB
19	1024	7	512	1023	17	60 MB
20	733	5	300	732	17	30 MB
21	733	7	300	732	17	43 MB
22	733	5	300	733	17	30 MB
23	306	4	0	336	17	10 MB
24	925	7	0	925	17	54 MB
25	925	9	65535	925	17	69 MB
26	754	7	754	754	17	44 MB
27	754	11	65535	754	17	69 MB
28	699	7	256	699	17	41 MB
29	823	10	65535	823	17	68 MB
30	918	7	918	918	17	53 MB
31	1024	11	65535	1024	17	94 MB
32	1024	15	65535	1024	17	128 MB
33	1024	5	1024	1024	17	43 MB
34	612	2	128	612	17	10 MB
35	1024	9	65535	1024	17	77 MB
36	1024	8	512	1024	17	68 MB
37	615	8	128	615	17	41 MB
38	987	3	987	987	17	25 MB
39	987	7	987	987	17	57 MB
40	820	6	820	820	17	41 MB
41	977	5	977	977	17	41 MB
42	981	5	981	981	17	41 MB
43	830	7	512	830	17	48 MB
44	830	10	65535	830	17	69 MB
45	917	15	65535	918	17	114 MB
46	1224	15	65535	1223	17	152 MB
47	USER-DEFINED HARD DRIVE - Enter user-supplied parameters.					

Advanced Setup

Advanced Setup options are displayed by choosing the Advanced icon from the WINBIOS Setup main menu. All Advanced Setup options are described in this section.

Typematic Rate This option sets the rate at which characters on the screen repeat when a key is pressed and held down. The settings are *Disabled*, *15*, *20*, or *30* characters per second.

The Optimal default setting is *20*. The Fail-Safe default setting is *Disabled*.

System Keyboard This option does not specify if a keyboard is attached to the computer. Rather, it specifies if error messages are displayed if a keyboard is not attached. This option permits you to configure workstations with no keyboards. The settings are *Absent* or *Present*.

The Optimal and Fail-Safe default settings are *Present*.

Primary Display This option configures the type of monitor attached to the computer. The settings are *Mono*, *CGA40x25*, *CGA80x25*, *VGA/EGA*, or *Absent*. The Optimal and Fail-Safe default settings are *VGA/EGA*.

Mouse Support When this option is enabled, AMIBIOS supports a PS/2-type mouse. Pins 1-13 on the motherboard must be shorted together to enable PS/2 mouse support. The settings are *Enabled* or *Disabled*.

The Optimal default setting is *Enabled*. The Fail-Safe default setting is *Disabled*.

Cont'd

Advanced Setup, Continued

Above 1 MB Memory Test When this option is enabled, the BIOS memory test is performed on all system memory. When this option is disabled, the memory test is done only on the first 1 MB of system memory. The settings are *Enabled* or *Disabled*. The Optimal and Fail-Safe default settings are *Disabled*.

Memory Test Tick Sound This option enables (turns on) or disables (turns off) the ticking sound during the memory test. The settings are *Enabled* or *Disabled*. The Optimal and Fail-Safe default settings are *Enabled*.

Parity Error Check This option enables parity error checking for system memory. The settings are *Enabled* (the parity for all system memory is checked) or *Disabled* (parity is checked only on the first 1 MB of system RAM).

The Optimal and Fail-Safe default settings are *Disabled*.

Hit Message Display Disabling this option prevents Hit if you want to run Setup from appearing when the system boots. The settings are *Enabled* or *Disabled*. The Optimal and Fail-Safe default settings are *Enabled*.

Cont'd

Advanced Setup, Continued

Extended BIOS RAM Area Specify if the top 1 KB of the system programming area beginning at 639K or 0:300 in the BIOS area in low memory will be used to store hard disk information. The settings are *On* or *0:300*.

The Optimal and Fail-Safe default settings are *0:300*.

Wait for <F1> If Any Error AMIBIOS POST runs system diagnostic tests that can generate a message followed by:

Press <F1> to continue

If this option is enabled, AMIBIOS waits for the end user to press <F1> before continuing. If this option is disabled, AMIBIOS continues the boot process without waiting for <F1> to be pressed. The settings are *Enabled* or *Disabled*. The Optimal and Fail-Safe default settings are *Enabled*.

System Boot UP/Num Lock When *On*, this option turns off the Num Lock key when the system is powered on so the end user can use the arrow keys on both the numeric keypad and the keyboard.

The settings are *On* or *Off*. The Optimal default setting is *Off*. The Fail-Safe default setting is *On*.

OS/2 Compatible Mode Set this option to *Enabled* if running OS/2 operating system and using more than 64 MB of system memory on the motherboard. The settings are *Enabled* or *Disabled*. The Optimal and Fail-Safe default settings are *Disabled*.

Floppy Drive Seek At Boot When this option is enabled, AMIBIOS performs a Seek command on floppy drive A: before booting the system. The settings are *Enabled* or *Disabled*. The Optimal default setting is *Disabled*. The Fail-Safe default setting is *Enabled*.

Cont'd

Advanced Setup, Continued

Floppy Drive Swapping Set this option to *Enabled* to permit drives A: and B: to be swapped. The settings are *Enabled* or *Disabled*. The Optimal and Fail-Safe default settings are *Disabled*.

System Boot Up Sequence This option sets the sequence of boot drives (either floppy drive A: or hard disk drive C:). AMIBIOS attempts to boot from after AMIBIOS POST completes. The settings are *A: or A:, C:* or *C: or A:, C:*. The Optimal default setting is *A:, C:*. The Fail-Safe default setting is *A:, C:*.

Base Memory Set this option to the amount of base system memory in the computer. The settings are *512KB* or *640KB*. The Optimal and Fail-Safe default settings are *640KB*.

Password Checking This option enables the password check option every time the system boots or the end user runs Setup. If *Always* is chosen, a user password prompt appears every time the computer is turned on. If *Setup* is chosen, the password prompt appears if WINBIOS is executed. See page 89 for instructions on changing a password.

The Optimal and Power-On default settings are *Setup*.

Internal Cache Set this option to *Enabled* to enable L1 internal cache memory. L1 cache memory is on the CPU. The settings are *Enabled* or *Disabled*. The Optimal default setting is *Enabled*. The Fail-Safe default setting is *Disabled*.

External Cache Set this option to *Enabled* to enable L2 secondary (external) cache memory. The settings are *Enabled* or *Disabled*. The Optimal default setting is *Enabled*. The Fail-Safe default setting is *Disabled*.

Cont'd

Advanced Setup, Continued

System BIOS Cacheable When this option is set to *Enabled*, the contents of the F0000h system memory segment can be read from or written to L2 secondary cache memory. The contents of the F0000h memory segment are always copied from the BIOS ROM to system RAM for faster execution. The settings are *Enabled* or *Disabled*. The Optimal default setting is *Enabled*. The Fail-Safe default setting is *Disabled*.

Video BIOS Cacheable When this option is set to *Enabled*, the contents of the C00000h – C8000h RAM area can be read from or written to L2 secondary cache memory. The contents of this memory are in RAM if the setting of the **Video Shadow C000,32K** option (see below) is set to *Enabled*. The settings are *Enabled* or *Disabled*. The Optimal default setting is *Enabled*. The Fail-Safe default setting is *Disabled*.

System Using Cache Controller Set this option to *Yes* if a cache controller is installed in the computer.

Setting	Description
<i>No</i> (the default setting)	To comply with the PCI specifications, PCI adapter cards must be reset every time the CPU is reset. When the end user forces a soft reset by pressing <Ctrl> <Alt> , only the CPU is reset. When this option is set to No, all soft resets are converted to hard resets, and all PCI adapter cards are reset when the CPU is reset.
<i>Yes</i>	Soft resets still behave like soft resets when Yes is selected. Select this option if a caching controller is installed in the computer. Soft resets must not generate a hard reset if a caching controller is used. If a hard reset is generated, a PCI caching controller card cannot flush data from cache memory to a hard disk drive before the reset.

Cont'd

Advanced Setup, Continued

Video ROM C000,32K This option controls the location of the contents of video ROM. The settings are:

Setting	Description
<i>Enabled</i>	The contents of the video ROM area (C0000h - C7FFFh) are written to the same address in RAM.
<i>Disabled</i>	The video ROM is not copied to RAM. The contents of the video ROM cannot be read from or written to cache memory.

The Optimal default setting is *Enabled*. The Fail-Safe default setting is *Disabled*.

Adaptor ROM CC00, 16K

Adaptor ROM D000, 16K

Adaptor ROM D400, 16K

Adaptor ROM D800, 16K

Adaptor Shadow DC00,16K These options enable shadowing of the contents of the ROM area in the option title.

Setting	Description
<i>Enabled</i>	The contents of the video ROM area (C000h - C7FFFh) are written to the same address in RAM for faster execution.
<i>Disabled</i>	The video ROM is not copied to RAM. The contents of the video ROM cannot be read from or written to cache.

The Optimal and Fail-Safe setting is *Disabled*.

IRQ 3

IRQ 4

IRQ 5

IRQ 7

IRQ 9

IRQ 10

IRQ 11

IRQ 12

IRQ 14

IRQ 15

These options specify the bus the specified IRQ can be used on. These options are primarily used to reserve an IRQ line for a legacy ISA adapter card. The settings are *PCI/PnP* or *ISA*. The Optimal and Fail-Safe default setting is *PCI/PnP* for all options.

Chipset Setup

Cache Module Type This option specifies the type of cache module installed on the motherboard. See page 16 through 18 for additional information about installing the cache module. Before selecting the cache module type, disable the onboard SMT cache memory by shorting Pins 2-3 of J30 on the motherboard.

The settings are *None*, *Async*, *Burst*, or *Pipeline*. The Optimal default setting is *Async*. The Fail-Safe default setting is *None*.

DRAM Speed for EDO If using EDO SIMMs for system memory, specify the RAS access speed of the EDO SIMMs installed in the motherboard. The settings are *60 ns* or *70 ns*. The default is *70 ns*.



Important

The **DRAM Speed for EDO** and **DRAM Speed for Fast Page Mode** options are only present if you have installed one bank of EDO SIMMs and one bank of fast page mode SIMMs. If only EDO SIMMs or only fast page mode SIMMs are installed in both memory banks, only the relevant option is displayed in Chipset Setup.

DRAM Speed for Fast Page Mode If using Fast Page Mode SIMMs for system memory, specify the RAS access speed of the Fast Page Mode SIMMs installed in the motherboard. The settings are *60 ns* or *70 ns*. The default is *70 ns*.

8 Bit I/O Recovery This option specifies the length of the delay that is added to the CPU cycle between consecutive 8-bit I/O operations. The length of the delay is related to the CPU type and frequency. The settings are *8* or *3 BCLK*, *5 BCLK*, *4 BCLK*, or *3 BCLK*. The Optimal default setting is *3 BCLK*. The Fail-Safe default setting is *8 BCLK*.

Cont'd

Chipset Setup, Continued

16 Bit I/O Recovery This option specifies the length of the delay that is added to the CPU cycle between consecutive 16-bit I/O operations. The length of the delay is related to the CPU type and frequency. The settings are *5 BCLK*, *4 BCLK*, *3 BCLK*, or *2 BCLK*. The Optimal default setting is *3 BCLK*. The Fail-Safe default setting is *5 BCLK*.

CPU To PCI Post Write This option specifies the length of a delay inserted before a posted write from the CPU to the PCI local bus. The settings are *Disabled*, *4 CPUCLK*, or *3 CPUCLK*. The Optimal default setting is *3 CPUCLK*. The Fail-Safe default setting is *Disabled*.

CPU To PCI Burst Write This option specifies the length of a delay inserted before a burst write from the CPU to the PCI local bus. The settings are *Disabled* or *Enabled*. The Optimal and Fail-Safe default settings are *Disabled*.

Max Burst Range in PCI Master This option specifies the maximum number of bytes that can be transferred in the PCI Master channel. The settings are *256 bytes*, *512 bytes*, *1 KB*, *2 KB*, or *4 KB*. The Optimal default setting is *1 KB*. The Fail-Safe default setting is *256 bytes*.

PCI VGA Palette Snoop This option must be set *Enabled* if any ISA adapter card installed in the computer requires VGA palette snooping.

The settings are *Enabled* or *Disabled*. The Optimal and Fail-Safe default settings are *Disabled*.

Cont'd

Chipset Setup, Continued

PCI Master Read Advanced Snooping This option is *Enabled* to enable advanced snoop reading in the PCI master channel. The settings are *Enabled* or *Disabled*. The Optimal default setting is *Enabled*. The Fail-Safe default setting is *Disabled*.

PCI Master Write Advanced Snooping This option is *Enabled* to enable advanced snoop writing in the PCI master channel. The settings are *Enabled* or *Disabled*. The Optimal and Fail-Safe default settings are *Disabled*.

Slot 1 Latency Timer

Slot 2 Latency Timer

Slot 3 Latency Timer

Slot 4 Latency Timer These options specify the latency period for PCI devices using PCI slots 1 – 4. The settings are *40 CLKs*, *80 CLKs*, *120 CLKs*, *160 CLKs*, *200 CLKs*, *220 CLKs*, or *240 CLKs*. The Optimal default setting is *240 CLKs*. The Fail-Safe default setting is *40 CLKs*.

ISA Memory Block Base This option specifies a block of RAM memory used as a base address for ISA adapter cards. The settings are *Disabled*, *C800h*, *CC00h*, *D000h*, *D400h*, *D800h*, or *DC00h*. The Optimal and Fail-Safe default settings are *Disabled*.

Reserved ISA Memory Block Size This option sets the size of the reserved ISA memory block. The settings are *Disabled* (only if the **ISA Memory Block Base** option is set to *Disabled*), *8KB*, *16KB*, *32KB*, or *64KB*. The Optimal default setting is *8KB*. The Fail-Safe default setting is *Disabled*.

Cont'd

Chipset Setup, Continued

Non-Cacheable Block1

Non-Cacheable Block2 These options specify how non-cacheable memory blocks 1 and 2 are used. The settings are:

Setting	Description
<i>Disabled</i>	This block of memory is not used.
<i>DRAM</i>	This block of memory can be used for system memory.
<i>PCI Bus</i>	This block of memory can be used on the PCI local bus.

Block Size

Block Size

If the **Non-Cacheable Block1** or **Non-Cacheable Block 2** options are set to *DRAM* or *PCI Bus*, these options can be selected. These options specify the size of the respective non-cacheable areas. The settings are *64 KB, 128 KB, 256 KB, 512 KB, 1 MB, 2 MB, 4 MB, or 8 MB*. The Optimal and Fail-Safe default settings are *64 KB*.

Block Base

Block Base

If the **Non-Cacheable Block1** or **Non-Cacheable Block 2** options are set to *DRAM* or *PCI Bus*, these options can be selected. These options specify the starting address of the respective non-cacheable areas. The settings are *2 MB through 131008 KB in 64 KB increments*. The Optimal and Fail-Safe default settings are *2 MB*.

Power Management Setup

Power Management Setup options are displayed by choosing the Power Mgmt icon on WINBIOS Setup. Power Management Setup options are:

Power Management/APM Set this option to *Enabled* to enable the power management and APM (Advanced Power Management) features. If this option is set to *Disabled*, all Optimal and Fail-Safe default settings for all other Power Management Setup options are set to *N/A*. The settings are *Enabled* or *Disabled*. The default settings are *Disabled*.

Instant On Support Set this option to *Enabled* to allow the computer to go to full power on mode when leaving a low-power state. The settings are *Enabled* or *Disabled*. The default settings are *Disabled*.

Green PC Monitor Power State This option specifies the power management state the Green PC-compliant video monitor enters after the specified period of display inactivity has expired. The settings are *Disabled*, *Off*, *Standby*, or *Suspend*. The Optimal and Fail-Safe default settings are *Disabled*.

Video Power Down Mode This option specifies the power management state in which the Green PC monitor is either turned off or enters Suspend or Standby mode. The setting of this option depends on the setting of **Green PC Monitor Power State** option. The settings are:

Setting	Description
<i>Disabled</i>	The video subsystem does not power down when the computer enters a power saving mode.
<i>Standby</i>	The video subsystem will power down when the computer enters Standby mode.
<i>Suspend</i>	The video subsystem will power down when the computer enters Suspend mode.

The Optimal and Fail-Safe defaults are *Disabled*.

Cont'd

Power Management Setup, Continued

Hard Disk Power Down Mode This option specifies the power management state in which the hard disk drive will be powered down. The settings are:

Setting	Description
<i>Disabled</i>	The hard disk drive does not power down when the computer enters a power saving mode.
<i>Standby</i>	The hard disk drive will power down when the computer enters Standby mode.
<i>Suspend</i>	The hard disk drive will power down when the computer enters Suspend mode.

The Optimal and Fail-Safe default settings are *Disabled*.

Hard Disk Timeout (Min) This option specifies the length of a period of hard disk inactivity. When this period expires, the hard disk drive enters the power-conserving mode specified in the **Hard Disk Power Down Mode** option described on the previous page. The settings are *Disabled*, *1 Min (minutes)*, and all one minute intervals up to and including *15 Min*. The default settings are *Disabled*.

Standby to Suspend Timeout This option specifies the length of the period of system inactivity when the computer is already in Standby mode before the computer is placed in Suspend mode. In Suspend mode, nearly all power use is curtailed. The settings are *Disabled*, *1 Min*, *2 Min*, and all one-minute intervals up to and including *15 Min*. The default settings are *Disabled*.

Cont'd

Power Management Setup, Continued

Slow Clock Ratio This option specifies the speed at which the system clock runs in Standby mode. In Suspend mode, the CPU clock is completely stopped. The settings are expressed as a ratio between the normal clock speed and the power down clock speed. The settings are *1:1, 1:2* (half as fast as normal), *1:4* (¼ the normal clock speed), *1:8, 1:16, 1:32, 1:64, or 1:128*. The default setting is *1:1*.

Display Activity This option specifies if AMIBIOS is to monitor activity on the display monitor for power conservation purposes. When this option is set to *Monitor* and there is no display activity for the length of time specified in the value of the **Full-On to Standby Timeout (Min)** option, the computer enters a power saving state. The settings are *Monitor* or *Ignore*. The default setting is *Ignore*.

IRQ 3
IRQ 4
IRQ 5
IRQ 7
IRQ 9
IRQ 10
IRQ 11
IRQ 12
IRQ 13
IRQ 14
IRQ 15

Before entering Suspend mode, AMIBIOS monitors the above IRQs for the length of time specified in the **Standby to Suspend Timeout** option if the IRQ option is set to *Monitor*. If all monitored IRQs are inactive for this length of time, AMIBIOS enters Suspend mode. Once the system is in Suspend mode, AMIBIOS monitors IRQs that have the corresponding option listed above set to *Monitor*. The system exits Suspend mode if any activity occurs on any IRQ set to *Monitor*.

Each of these options can be set to *Monitor* or *Ignore*. The default setting for all options is *Ignore*.

Peripheral Setup

Peripheral Setup options are displayed by choosing the Peripheral Setup icon from the WINBIOS Setup main menu. All Peripheral Setup options are described in this section.

IDE Terminology Peripheral Setup includes options related to IDE controllers and IDE drives. First, definitions for IDE terms are provided.

Term	Description
Onboard	The IDE controllers on the Atlas PCI-II motherboard. There is a primary and a secondary IDE controller on the motherboard. Each IDE controller supports up to two IDE devices.
Offboard	The IDE controllers on an IDE controller adapter card inserted in an ISA or PCI expansion slot. AMIBIOS supports primary and a secondary offboard IDE controller. Each IDE controller supports up to two IDE devices.
Primary Controller	Whether using an onboard or an offboard IDE controller, one of the IDE controllers is the primary controller.
Secondary Controller	The second IDE controller is the secondary controller.
Master Drive	Each IDE controller can have two drives attached to it. The first drive is the Master drive.
Slave Drive	Each IDE controller can have two drives attached to it. The second drive is the Slave drive.

Cont'd

Peripheral Setup, Continued

IDE Controller Settings The following characteristics can be selected for the Onboard Primary, Onboard Secondary, Offboard Primary, and Offboard Secondary IDE controllers:

Peripheral Setup Option	Description
IDE LBA Mode	<p>Use this option to enable IDE LBA (Logical Block Addressing) mode. Older hard disk drives use the CHS (Cylinder-Head-Sector) addressing scheme that limits hard disk drives to 528 MB. LBA permits drives capacities up to 5 GB.</p> <p>Setting Description</p> <p><i>Disabled</i> Do not enable IDE LBA mode (Default).</p> <p><i>Master</i> Enable IDE LBA mode for the master IDE drive attached to the primary IDE controller.</p> <p><i>Slave</i> Enable IDE LBA mode for the slave IDE drive attached to the primary IDE controller.</p> <p><i>Both</i> Enable IDE LBA mode for both the Primary and Secondary IDE controller are enabled.</p>

Peripheral Setup Option	Description
IDE Block Mode	<p>IDE Block mode enables higher data transfer rates.</p> <p>Setting Description</p> <p><i>Disabled</i> Do not enable IDE Block Mode (Default).</p> <p><i>Master</i> Enable IDE Block Mode for the master IDE drive attached to the primary IDE controller.</p> <p><i>Slave</i> Enable IDE Block Mode for the slave IDE drive attached to the primary IDE controller.</p> <p><i>Both</i> Enable IDE Block IDE Mode for both the Primary and Secondary IDE controller are enabled.</p>
IDE 32-Bit Transfer	<p>32-bit data transfers move twice as much data to and from the IDE drives.</p> <p>Setting Description</p> <p><i>Disabled</i> Do not enable IDE 32-bit transfers (Default).</p> <p><i>Master</i> Enable IDE 32-bit transfers for the master IDE drive attached to the primary IDE controller.</p> <p><i>Slave</i> Enable IDE 32-bit transfers for the slave IDE drive attached to the primary IDE controller.</p> <p><i>Both</i> Enable IDE 32-bit transfers for both the primary and secondary IDE controllers.</p>

Peripheral Setup Option	Description
<p>IDE Prefetch</p>	<p><i>Not available for Offboard Primary and Offboard Secondary IDE Controller.</i></p> <p>IDE prefetch mode reads part of the data from the IDE drive before the CPU actually asks for the data. This mechanism makes data reads faster when large blocks of data are read.</p> <p>Setting Description</p> <p><i>Disabled</i> Do not enable IDE prefetch mode (Default) <i>You must use this setting if loading the OS/2 IDE device drivers.</i></p> <p><i>Master</i> Enable IDE prefetch mode for the master IDE drive attached to the primary IDE controller.</p> <p><i>Slave</i> Enable IDE prefetch mode for the slave IDE drive attached to the primary IDE controller.</p> <p><i>Both</i> Enable IDE prefetch mode for both the Primary and Secondary IDE controller</p>
<p>Onboard Primary/ Onboard Secondary IDE Post Write</p>	<p>You can enable or disable posted writes to the specified IDE drive through these options. The settings are <i>Enabled</i> or <i>Disabled</i>.</p>

Peripheral Setup Option	Description
IDE Master/Slave PIO	<p data-bbox="447 185 859 240"><i>Not available for Offboard Primary and Offboard Secondary IDE Controller.</i></p> <p data-bbox="447 280 976 589">The IDE PIO (Programmed I/O) mode is a standard for information storage and retrieval. In general, higher modes provided better performance than lower modes. The PIO mode for all IDE drives is set at the factory and cannot be changed. You must choose the proper PIO mode or your IDE drive will not work and may be damaged. If you choose Auto, AMIBIOS will automatically select the correct IDE PIO mode.</p> <p data-bbox="447 630 676 656">Setting Description</p> <p data-bbox="447 662 995 846"><i>Auto</i> Permit AMIBIOS to determine the optimal IDE mode supported by the IDE drive installed as the primary IDE master drive (Default).</p> <p data-bbox="447 852 783 878"><i>Mode 0</i> Specify IDE mode 0.</p> <p data-bbox="447 885 783 911"><i>Mode 1</i> Specify IDE mode 1.</p> <p data-bbox="447 917 783 943"><i>Mode 2</i> Specify IDE mode 2.</p> <p data-bbox="447 950 783 976"><i>Mode 3</i> Specify IDE mode 3.</p> <p data-bbox="447 982 783 1008"><i>Mode 4</i> Specify IDE mode 4.</p>
Offboard PCI/ISA IDE	<p data-bbox="447 1018 937 1138">Use this option if you want to use an IDE controller card installed in an ISA or PCI expansion slot. The settings are <i>Absent</i>, <i>ISA</i>, <i>Slot 1</i>, or <i>Slot 2</i>. The default setting is <i>Absent</i>.</p> <p data-bbox="447 1179 910 1263">If ISA is selected the Offboard Primary/Secondary IDE option becomes available.</p>
Onboard IDE Burst Mode	<p data-bbox="447 1273 687 1295">The settings are N/A.</p>

Peripheral Setup Option	Description
Offboard IDE INT# Line	<p data-bbox="330 185 756 245"><i>Only available for Offboard Primary and Offboard Secondary IDE Controller.</i></p> <p data-bbox="330 282 838 402">Use this option to specify the PCI interrupt used by the offboard PCI IDE controller (if installed). The settings are <i>INTA</i>, <i>INTB</i>, <i>INTC</i>, <i>INTD</i>, or <i>Not Used</i>. The default setting is <i>INTA</i>.</p>

Cont'd

Peripheral Setup, Continued

Onboard Primary/Secondary Controller The Peripheral Setup IDE options that become available depends on the onboard IDE controllers you enable:

Controller	Peripheral Setup IDE Options
Only Primary	<p>Set Onboard Primary/Secondary IDE to <i>Primary</i>. The following options become available:</p> <p>Onboard Primary LBA Mode, Onboard Primary Block Mode, Onboard Primary 32-Bit Transfer, Onboard Primary Prefetch, Onboard Primary Post Write Onboard Primary Master PIO, and Onboard Primary Slave PIO.</p>
Primary and Secondary (Both)	<p>Set Onboard Primary/Secondary IDE to <i>Both</i>. The Onboard Secondary Drives Present option will be available if the secondary IDE controller is used and the Onboard Primary/Secondary IDE options set to <i>Secondary</i> or <i>Both</i>. Specify the number of IDE drives attached to the Secondary IDE controller.</p> <p>The settings are <i>None</i>, <i>1 Drive</i>, or <i>2 Drives</i>. The default setting is <i>None</i>. If <i>1 Drive</i> or <i>2 Drives</i> is selected, the following options become available:</p> <p>Onboard Primary LBA Mode, Onboard Primary Block Mode, Onboard Primary 32-Bit Transfer, Onboard Primary Prefetch, Onboard Primary Post Write Onboard Primary Master PIO, Onboard Primary Slave PIO. Onboard Secondary Drives Present, Onboard Secondary LBA Mode, Onboard Secondary Block Mode, Onboard Secondary 32-Bit Transfer, Onboard Secondary Prefetch, Onboard Secondary Master PIO, and Onboard Secondary Slave PIO.</p>

Controller	Peripheral Setup IDE Options
Secondary	<p>Set Onboard Primary/Secondary IDE to <i>Secondary</i>. The Onboard Secondary Drives Present option will be available if the secondary IDE controller is used and the Onboard Primary/Secondary IDE options set to <i>Secondary</i>. Specify the number of IDE drives attached to the Secondary IDE controller. The settings are <i>None, 1 Drive</i> , or <i>2 Drives</i> . The following options become available:</p> <p>Onboard Secondary Drives Present, Onboard Secondary LBA Mode, Onboard Secondary Block Mode, Onboard Secondary 32-Bit Transfer, Onboard Secondary Prefetch, Onboard Secondary Master PIO, and Onboard Secondary Slave PIO.</p>

Peripheral Setup, Continued

Offboard Primary/Secondary Controller The IDE options that become available depend on the enabled offboard IDE controllers. **Onboard Primary/Secondary IDE** to *Disabled*. Set **Offboard PCI/ISA IDE**

- *ISA* if an ISA IDE card is installed in an ISA expansion slot.
- *Slot 1* if a PCI IDE card is installed in PCI expansion slot 1.
- *Slot 2* if a PCI IDE card is installed in PCI expansion slot 2.

Controller	Peripheral Setup IDE Options
Primary	Set Offboard Primary/Secondary IDE to <i>Primary</i> . The following options become available: Offboard Primary LBA Mode, Offboard Primary Block Mode, Offboard Primary 32-Bit Transfer, and Offboard Primary IDE INT Number Line.
Primary and Secondary (Both)	Set Offboard Primary/Secondary IDE to <i>Both</i> . Set Offboard Secondary Drives Present to <i>1 Drive</i> or <i>2 Drives</i> . The following options become available: Offboard Primary LBA Mode, Offboard Primary Block Mode, Offboard Primary 32-Bit Transfer, Offboard Primary IDE INT Number Line, Offboard Secondary LBA Mode, Offboard Secondary Block Mode, Offboard Secondary 32-Bit Transfer, Offboard Secondary IDE INT Number Line.
Secondary	Set Onboard Primary/Secondary IDE to <i>Secondary</i> . Set Offboard Secondary Drives Present to <i>1 Drive</i> or <i>2 Drives</i> . The following are available: Offboard Secondary LBA Mode, Offboard Secondary Block Mode, Offboard Secondary 32-Bit Transfer, Offboard Secondary IDE INT Number Line.

Cont'd

Peripheral Setup, Continued

Offboard PCI IDE Controller Only following Peripheral Setup options only appear if an offboard PCI IDE controller card is used:

- Offboard Primary 32-Bit Transfer,
 - Offboard Secondary 32-Bit Transfer,
 - Offboard Primary INT Number Line, and
 - Offboard Secondary INT Number Line.
-

Onboard Floppy Controller This option enables the floppy drive controller on the motherboard. The settings are *Enabled* or *Disabled*. The Optimal and Fail-Safe default settings are *Enabled*.

Serial Port1 IRQ This option specifies the IRQ (Interrupt Request Line) used by serial port 1. The settings are *IRQ 4* or *Disabled*. The Optimal default setting is *IRQ 4*. The Fail-Safe default setting is *Disabled*.

Serial Port1 Address This option specifies the base I/O port address for serial port 1. The settings are *3F8h*, *3F8h*, or *Disabled*. The Optimal default setting is *3F8h*. The Fail-Safe default setting is *N/A*.

Serial Port1 FIFO This option enables the FIFO buffer for the first serial port. The settings are *Enabled* or *Disabled*. The Optimal default setting is *Disabled*. The Fail-Safe default setting is *N/A*.

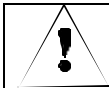

Caution

Do not enable the Serial Port 1 FIFO option if a mouse is attached to COM1.

Serial Port2 IRQ This option specifies the IRQ (Interrupt Request Line) used by serial port 1. The settings are *IRQ 3* or *Disabled*. The Optimal default setting is *IRQ 3*. The Fail-Safe default setting is *Disabled*.

Cont'd

Peripheral Setup, Continued

Serial Port2 Address This option specifies the base I/O port address of serial port 2. The settings are *1F8h*, *2E8h*, or *Disabled*. The Optimal default setting is *1F8h*. The Fail-Safe default setting is *N/A*.

Serial Port2 FIFO This option enables the FIFO buffer for the second serial port. The settings are *Enabled* or *Disabled*. The Optimal default setting is *Disabled*. The Fail-Safe default setting is *N/A*.

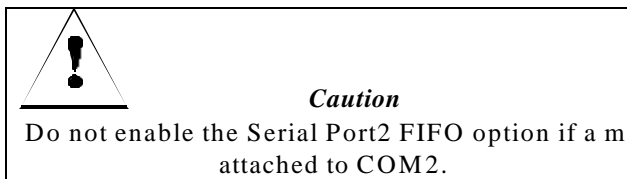

Parallel Port IRQ This option specifies the IRQ (Interrupt Request Line) used by the parallel port. The settings are *Disabled*, *IRQ 5*, or *IRQ 7*. The Optimal default setting is *IRQ 7*. The Fail-Safe default setting is *Disabled*.

Parallel Port Address This option specifies the base I/O port address for the parallel port. The settings are *378h*, *278h*, or *Disabled*. The Optimal default setting is *378h*. The Fail-Safe default setting is *N/A*.

Cont'd

Peripheral Setup, Continued

Parallel Port Mode This option specifies the parallel port mode. ECP and EPP are both bidirectional data transfer schemes that adhere to the IEEE P1284 specifications. The Optimal default setting is *Normal*. The Fail-Safe default setting is *Normal*. The settings are:

Setting	Description
<i>Normal</i>	The normal parallel port mode is used.
<i>Extended</i>	This setting supports bidirectional transfers on the parallel port.
<i>EPP</i>	The parallel port can be used with devices that adhere to the Enhanced Parallel Port (EPP) specification. EPP uses the existing parallel port signals to provide asymmetric bidirectional data transfer driven by the host device.
<i>ECP</i>	The parallel port can be used with devices that adhere to the Extended Capabilities Port (ECP) specification. ECP uses the DMA protocol to achieve transfer rates of approximately 2.5 Mbs. ECP provides symmetric bidirectional communications.

Parallel Port DMA This option is only available if the setting for the **Parallel Port Mode** option is *ECP*.

The settings are *DMA CH (channel) 0*, *DMA CH 1*, or *DMA CH 3*. The Optimal and Fail-Safe default setting is *DMA Ch 0*.

Section 2 Utility

The following icons appear in this section:

Detect C: if drive C: is an IDE drive, the hard disk drive parameters for drive C: are automatically detected and reported to the Hard Disk Drive C: screen in Standard Setup, so you can easily configure drive C:.

Detect D: if drive D: is an IDE drive, the hard disk drive parameters for drive D: are automatically detected and reported to the Hard Disk Drive D: screen in Standard Setup, so you can easily configure drive D:.

Color Set sets the WINBIOS Setup screen colors.

Section 3 Security

AMIBIOS Password Support

WINBIOS Setup has an optional password feature. The system can be configured so that all users must enter a password every time the system boots or when WINBIOS Setup is executed.

Setting a Password

The password check option is enabled in Advanced Setup (see page 59) by choosing either *Always* (the password prompt appears every time the system is powered on) or *Setup* (the password prompt appears only when WINBIOS is run). The password is encrypted and stored in CMOS RAM.

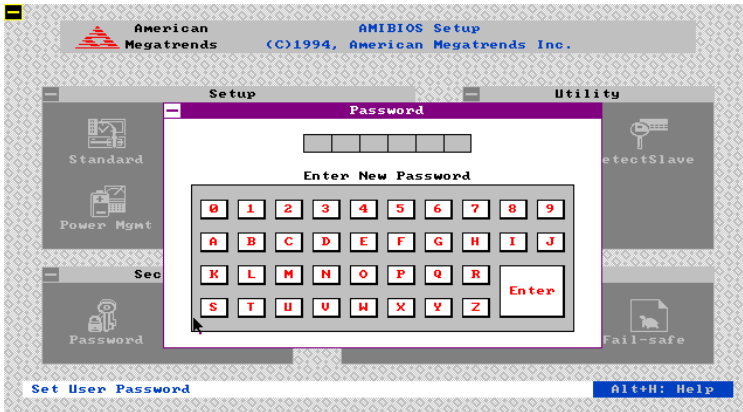

As shown on the above screen, you are prompted for a 1 – 6 character password. You can either type the password on the keyboard or select each letter of the password, one at a time, using the mouse. The password does not appear on the screen when typed. Make sure you write it down. If you forget it, you must drain CMOS RAM and reconfigure.

If You Do Not Want to Use a Password Just press <Enter> when the password prompt appears.

Changing a Password

Select the *Password* icon from the Security section of the WINBIOS Setup main menu. Enter the password and press <Enter>. The screen does not display the characters entered. After the new password is entered, retype the new password as prompted and press <Enter>.

If the password confirmation is incorrect, an error message appears. If the new password is entered without error, press <Esc> to return to the WINBIOS Main Menu. The password is stored in CMOS RAM after WINBIOS completes. The next time the system boots, you are prompted for the password if the password function is present and is enabled.

Remember the Password Keep a record of the new password when the password is changed. If you forget the password, remove the computer cover, set switch 1-2 (the DIAG switch) to ON, power on the computer. AMIBIOS will erase the password.

Anti-Virus

When this icon is selected from the Security section of the WINBIOS Setup main menu, AMIBIOS issues a warning when any program (or virus) issues a Disk Format command or attempts to write to the boot sector of the hard disk drive. The settings are *Enabled* or *Disabled*. If enabled, the following appears when a write is attempted to the boot sector. You may have to type several times to prevent the boot sector write.

```
Boot Sector Write!!!  
Possible VIRUS: Continue (Y/N)? _
```

The following appears after any attempt to format any cylinder, head, or sector of any hard disk drive via the BIOS INT 13 Hard Disk Drive Service:

```
Format!!!  
Possible VIRUS: Continue (Y/N)? _
```

Section 4 Default

The icons in this section permit you to select a group of settings for all WINBIOS Setup options. Not only can you use these icons to quickly set system configuration parameters, you can choose a group of settings that have a better chance of working when the system is having configuration-related problems.

Original Choose the Original icon to return to the system configuration values present in WINBIOS Setup when you first began this WINBIOS Setup session.

Optimal You can load the optimal default settings for the WINBIOS by selecting the Optimal icon. The Optimal default settings are best-case values that should optimize system performance. If CMOS RAM is corrupted, the Optimal settings are loaded automatically.

Fail-Safe You can load the Fail-Safe WINBIOS Setup option settings by selecting the Fail-Safe icon from the Default section of the WINBIOS Setup main menu.

The Fail-Safe settings provide far from optimal system performance, but are the most stable settings. Use this option as a diagnostic aid if the system is behaving erratically.

3 Programming the Flash ROM

All versions of the Atlas PCI-II motherboard use Flash EPROM to store the system BIOS. The advantage of Flash EPROM is the EPROM chip does not have to be replaced to update the BIOS. The end user can actually reprogram the BIOS, using a ROM file supplied by American Megatrends..

Programming the Flash EPROM

Step	Action
1	Turn power off. Make sure the computer has a working speaker.
2	Insert the floppy disk with the S727P.ROM file in drive A:.
3	Before DOS boots, press and hold down the <Ctrl> and <Home> keys to reprogram the Flash EPROM-based AMIBIOS. The bootblock code immediately reads the A: drive, looking for the new BIOS information.
4	When the flash ROM has successfully been programmed, the computer will reboot.

Boot Block BIOS Action: When you reprogram from system boot, the boot block BIOS code:

Reads S727P.ROM from the root directory of the floppy disk in drive A:.. Erases the Flash EPROM. Programs the Flash EPROM with the data read from the floppy disk in drive A:.. Generates a CPU reset, rebooting the computer.

The bootblock part of the Flash EPROM is not programmed. Should you inadvertently open the disk drive door or turn power off to the computer while programming the Flash EPROM, the bootblock will be unaffected. Simply turn power back on and begin the Flash ROM programming process again.

Cont'd

Programming the Flash ROM, Continued

S727P.ROM S727P.ROM resides on a floppy disk and contains the updated main BIOS code. American Megatrends will provide this file when the AMIBIOS for the Atlas PCI-II ISA motherboard must be updated.

S727P.ROM must be present in the root directory of the floppy disk before the onboard Flash EPROM can be reprogrammed. The file that has the main BIOS code must be named S727P.ROM.

Sequence of Operation The sequence of operation and expected behavior of the boot block BIOS code is:

Step	Expected behavior
1 Look for floppy disk.	The system beeps one time before the BIOS attempts to read from floppy drive A:.
2 Look for S727P.ROM on the floppy disk.	S727P.ROM must be in the root directory of the floppy disk in drive A:. There is no beep if successful.
3 Read the floppy disk.	The floppy disk is read. There is no beep if this step is successful.
4 Check for BIOS file size.	The BIOS file size is checked. There is no beep if this step is successful.
5 Check for Flash EPROM.	The BIOS looks for an Intel i28F001BX-T Flash EPROM. It does not beep if this step is successful.
6 Erase the Flash EPROM.	Two beeps sound when the BIOS begins erasing the Flash EPROM.
7 Program the Flash EPROM.	Three beeps sound when the AMIFlash Code begins reprogramming the Flash EPROM.
8 Continue programming the Flash EPROM.	Four beeps sound when reprogramming has been successfully completed.
9 AMIFlash does a reset.	A CPU reset is generated to reboot the computer.

Programming the Flash ROM, Continued

- Beep Codes** The bootblock code produces a series of beeps during Flash ROM programming to:
- signify completion of a step (as shown on the previous page), or to
 - signal an error.
- Error beeps are arranged in a coded sequence and have different meanings depending on when they occur. The error beep codes and when they can occur are:

Number of Beeps	Description
1	Insert diskette in floppy drive A:.
2	The AMIBOOT.ROM file was not found in the root directory of the diskette in floppy drive A:.
3	Base memory error.
4	Flash program successful.
5	Floppy read error.
6	Keyboard controller BAT command failed.
7	No Flash EPROM detected.
8	Floppy controller failure.
9	Boot Block BIOS checksum error.
10	Flash erase error.
11	Flash Program error.
12	AMIBOOT.ROM file size error.
Continuous beep	Flash Programming successful. Turn power off. The turn power on again to restart.

Bootblock Code Checkpoint Codes

Code	Description
E0h	Verify the Boot Block BIOS checksum. Disable the internal cache, DMA, and interrupt controllers. Initialize the system timer. Start memory refresh.
E1h	Initialize the chipset registers. Set the BIOS size to 128K. Make the 512 KB base memory available.
E2h	Test the base 64 KB of system memory. Send the BAT command to the keyboard controller. Make sure that <Ctrl> <Home> was pressed. Verify the system BIOS checksum.
E3h	The main system BIOS is good. Transfer control to the main system BIOS.
E4h	Start the memory test.
E5h	The memory test is over. Initialize the interrupt vector table.
E6h	Initialize the DMA and interrupt controllers.
E7h	Determine the CPU internal clock frequency.
E8h	Initialize the I/O chipset, if any.
E9h	Program the CPU clock-dependent chip set parameters.
EAh	Enable the timer and the floppy diskette interrupt. Enable the internal cache. Copy the boot block BIOS and pass control to the boot block BIOS in the 0000h segment.
EDh	Initialize the floppy drive.
EEh	Look for a diskette in drive A:. Read the first sector of the diskette.
EFh	Floppy read error.
F0h	Search for AMIBOOT.ROM in the root directory of the floppy diskette in drive A:.
F1h	The AMIBOOT.ROM file is not in the root directory.
F2h	Read the FAT table. Analyze the FAT to find the clusters occupied by the AMIBOOT.ROM.
F3h	Start reading the AMIBOOT.ROM file, cluster by cluster.
F4h	The AMIBOOT.ROM file is not the correct size.
F5h	Disable the internal cache. Raise the Vpp. Enable Flash write and reset the Flash ROM.
FBh	Detect the flash type.
FCh	Start erasing flash blocks.
FDh	Program the Flash ROM in the E0000-EFFFFh region.
FEh	Start programming Flash at F0000-FFFFFh region.
FFh	Flash programming is successful. The computer reboots.

A Specifications

Item	Description
CPU	Intel Pentium 75, 90, 100, 120, 133 MHz, or higher 3.3V CPU
Expansion slots	Four ISA expansion slots Four PCI expansion slots
L1 internal cache memory	The Intel Pentium has 8 KB data cache and 8 KB instruction cache.
L2 Secondary Cache memory	256 KB, 512 KB or 1 MB. 256 KB surface-mount SRAMDIPs.
Cache Memory /System memory	256 KB caches up to 64 MB of system memory 512 KB caches up to 128 MB of system memory 1 MB caches up to 256 MB of system memory
Type of SRAM	Secondary cache memory supported either through surface-mount SRAMDIPs or cache memory module.
System memory	Fast page mode or Extended Data Out (EDO) SIMMs operating at 70ns.
Memory Buffer	One level posted write memory buffer
Max. system memory	256 MB
Fast ATA	Supports the Fast ATA specification using PIO mode 4 and multiword DMA mode 2.
System BIOS	This motherboard has a 128 KB AMIBIOS system BIOS located on a Flash EEPROM with built-in WINBIOS Setup.
BIOS Shadowing	The system BIOS is always copied from ROM to RAM for faster execution. The end user can shadow 16 KB ROM segments from C000h – DCFFh.

Item	Description
AMIBIOS features	IDE block mode support, IDE 32-bit data transfer support, IDE Programmed I/O mode 0, 1, 2, 3, and 4 support, IDE LBA mode support, APM (Advanced Power Management) and Flash BIOS hooks, EPA Green PC-compliant, PCI and Plug and Play (PnP) support, and DIM (Device Initialization Manager) support, DMI (Desktop Management Interface) support, ATAPI support, can boot from a CD-ROM drive, automatically detects system memory, cache memory, and IDE drive parameters, Intel NSP-compliant, Fast ATA IDE mode programming, Boot sector virus protection, instant-on support, automatically configure PnP and PCI devices.
IDE	Provides two 40-pin IDE connectors onboard that support up to four IDE drives.
Floppy	Provides onboard supports up to two 360 KB, 720 KB, 1.2 MB, 1.44 MB, or 2.88 MB floppy drives.
Parallel port	Provides an onboard parallel port connector.
Serial ports	Provides two onboard serial port connectors.
Keyboard	Includes a standard mini-DIN keyboard connectors.
Mouse	Includes a 10-pin berg mouse connector.
Power supply	Includes three power supply connectors.
Real Time Clock/ CMOS RAM	A real time clock and 128 bytes of CMOS RAM with a battery backup is provided on the motherboard.
Power management	Power management services include: Green PC LED, power management signal to Green PC-aware power supplies, automatic IDE and video power down, monitor blanking, SMI (System Management Interrupt) support, APM, and system stop clock.
Speaker	Standard four-pin speaker connection.

Appendix B Configuring an Offboard IDE Controller

If you need to install IDE drives in the computer and you are not using the onboard PCI IDE controller on the Atlas PCI-II motherboard, you must configure an offboard IDE controller. The following instructions have been tested with TekRAM and BusLogic DC-690CD PIC IDE controller. Perform the following steps:

Step	Action
1	Install the IDE controller paddle card in an available PCI expansion slot.
2	Set the Peripheral Setup Offboard PCI/ISA IDE option in WINBIOS Setup to: <i>ISA</i> if an ISA IDE card is installed in an ISA expansion slot. <i>Slot 1</i> if a PCI IDE card is installed in PCI expansion slot 1. <i>Slot 2</i> if a PCI IDE card is installed in PCI expansion slot 2.
3	If installing a primary offboard IDE controller: set the WINBIOS Setup Peripheral Setup Offboard Primary LBA Mode, Offboard Primary Block Mode, and Offboard Primary 32-Bit Transfer Enabled .
4	Set the Offboard IDE INT# Line option in Peripheral Setup to <i>Not Used</i> .
5	In the TekRAM or BusLogic Setup program, set the INT 13h BIOS Selection option to <i>INT 13h Motherboard</i> .
6	Reboot the computer. Press to run WINBIOS Setup as prompted during system boot. Select Detect Master from the WINBIOS Setup main screen.
7	Press <Esc> and select Save Changes and Exit . The computer will reboot from the hard disk drive.

Index

—1—

16 Bit I/O Recovery, 53

—8—

8 Bit I/O Recovery, 52

—A—

Above 1 MB Memory Test, 47

Adaptor ROM D800, 16K, 51

Adaptor ROM CC00, 16K, 51

Adaptor ROM D000, 16K, 51

Adaptor ROM D400, 16K, 51

Adaptor Shadow DC00, 16K,
51

Advanced Power
Management, 56

Advanced Setup, 46

AMIFlash

Beep Codes, 75

Anti-Virus

WINBIOS Setup, 71

Auto Detect Hard Disk, 44

—B—

Base Memory, 49

BIOS

Password Support, 70

BIOS Errors, 37

Block Base, 55

Block Size, 55

—C—

Cables

Connecting, 20

Cache Module Type, 52

COM1, 29

COM2, 29

Configuring System, 37

Conflicts, 29

Appendix B Configuring onboard IDE Controller

Connectors

Floppy disk, 31

IDE Activity Indicator, 28

IDE Hard Disk Drive, 34

Keyboard, 25

Power supply, 24

Reset Switch, 27

Serial ports, 29

SIMM, 14

Speaker, 27

Turbo LED, 28

CPU To PCI Burst Write, 53

CPU To PCI Post Write, 53

—D—

Default Settings

WINBIOS Setup, 72

Dimensions, 2

Display Activity, 58

DRAM Speed for EDO, 52

DRAM Speed for Fast Page
Mode, 52

—E—

Extended BIOS RAM Area, 48

External Cache, 49

—F—

Fail-Safe BIOS Setup Settings

WINBIOS Setup, 72

Figures

Floppy drive cable, 31

Floppy drive connector,
31

Power supply key cutting,
24

Reset switch connector,
27

Speaker connector, 27

- Turbo LED connector, 28
- First Serial Port FIFO, 66
- Flash EPROM
 - Programming, 73
- Floppy Disk
 - Seek at Boot, 48
- Floppy Disk Connector
 - Pinout, 31
- Floppy Drive connector
 - Pinout, 32
- Floppy Drive Swapping, 49

—G—

- Green PC Monitor Power
 - State, 56

—H—

- Hard Disk Drive Capacity, 44
- Hard Disk Drive Parameters, 44
- Hard Disk Drive Type D:, 44
- Hard Disk Power Down Mode, 57
- Hard Disk Timeout (Min), 57
- Height restrictions, 2
- Hit if you want to run Setup, 47
- Hit Message Display, 47

—I—

- IDE Activity Indicator LED, 28
- IDE Drivers, 34
- IDE Hard Disk Connector, 34
- Install Memory, 12
- Installation, 3
- Installing Adapter Cards, 37
- Installing the Motherboard, 18
- Instant On Support, 56
- Internal Cache, 49
- IRQ 10, 51
- IRQ 11, 51
- IRQ 12, 51
- IRQ 14, 51

- IRQ 15, 51, 58
- IRQ 3, 51, 58
- IRQ 4, 51
- IRQ 5, 51
- IRQ 7, 51
- IRQ 9, 51
- ISA Memory Block Base, 54

—J—

- J1 Floppy Connector, 31
- J13 Parallel Port IRQ Select, 6
- J14 Serial Port 1 (COM1), 29
- J19 Serial Port 2 (COM2), 29
- J2 IDE Connector
 - Primary, 34
- J2 Pinout, 35
- J20, 46
- J20 Onboard PS/2 Mouse
 - Enable, 7
- J25 Green PC Monitor
 - Connector Pinout, 21
- J26 Keyboard Lock connector, 28
- J28 Reset Switch Connector, 27
- J31 Speaker Connector, 27
- J32 Turbo LED connector, 28
- J36 IDE Indicator LED, 28
- J37 Parallel Port connector, 30
- J4 Pinout, 36
- J4 Secondary IDE Controller, 35
- J44 Green PC Power, 27

—K—

- Keyboard, 46
- Keyboard connector, 25

—L—

- Landing Zone, 44

—M—

- Max Burst Range in PCI
 - Master, 53

- Memory
 - Reporting, 12
- Memory Test Tick Sound, 47
- Monitor, 46
- Motherboard
 - Dimensions, 2
 - Height restrictions, 2
- Mouse Support, 46

—N—

- Non-Cacheable Block1, 55
- Non-Cacheable Block2, 55
- Number of Cylinders, 44
- Number of Heads, 44
- Number of Sectors, 44

—O—

- Onboard Adapters, 29
- On-Board Floppy, 66
- Optimal default settings
 - WINBIOS Setup, 72
- Original, 72
- OS/2 Compatible Mode, 48
- Overview, 1

—P—

- P3 Pinout, 25
- Parallel Port, 30
- Parallel Port Address, 67
- Parity Error Check, 47
- Password Checking, 49
- PCI Master Read Advanced
 - Snoop, 54
- PCI Master Write Advanced
 - Snoop, 54
- PCI VGA Palette Snoop, 53
- Peripheral Setup, 59
- Pinout
 - J4 Secondary IDE
 - connector, 36
 - Parallel Port, 30
 - Power supply, 25
 - Primary IDE connector, 35
 - Serial ports, 29

Pinouts

- IDE Activity Indicator, 28
- Keyboard lock, 28
- P1 Power Supply, 24
- P2 Power Supply, 24, 25
- Reset Switch, 27
- Serial ports, 29
- Turbo LED, 28
- Power Management Setup, 56
- Power Supply, 23
 - Connecting, 23
 - Pinouts, 24
- Primary Display, 46

—R—

- Reporting Memory, 12
- Reset Switch Connector, 27
- Resource conflicts, 29

—S—

- S725P.ROM, 74
- Secondary IDE Controller, 35
- Serial port
 - Pinout, 29
- Serial Port1 Address, 66
- Serial Port1 IRQ, 66
- Serial Port2 FIFO, 67
- Serial Port2 IRQ, 66, 67
- Setup
 - Wait for F1 If Any Error, 48
- SIMM Part Numbers, 13
- SIMMs
 - Installing, 14
 - Part numbers, 13
 - Selecting, 12
- Slot 1 Latency Timer, 54
- Slot 2 Latency Timer, 54
- Slot 3 Latency Timer, 54
- Slot 4 Latency Timer, 54
- Slow Clock Ratio, 58
- Speaker Cable Connector, 27
- Standard Setup, 43

Standby to Suspend Timeout,
57
System BIOS Cacheable, 50
System Boot Up Num Lock, 48
System Boot Up Sequence, 49
System Using Cache
Controller, 50

—T—

Tables

Floppy pinout, 32
Hard Disk Drive Types,
45
I/O conflicts, 29
Memory parameters, 12
P1 Pinout, 24
P2 Pinout, 24, 25
Serial port pinout, 29
Speaker connector
pinout, 27
Steps for installing
motherboard, 18
Twist in floppy cable, 32
Testing System, 37
Turbo LED, 28
Typematic Rate, 46

—U—

Unpack the Motherboard, 5
Utility
WINBIOS Setup, 69

—V—

VGA Memory
Upgrading, 77
Video BIOS Cacheable, 50
Video Power Down Mode, 56
Video ROM C000,32K, 51

—W—

Wait for F1 If Any Error, 48
WINBIOS Setup, 39
Write Precompensation, 44

